

# Adams



**V**olumetric systems are mainly used for bearing and slideway lubrication on machine tools, this is a positive displacement system delivering specific amounts of lubricant to the required points. Two types of metering valves are available: the Direct type which operate on full line pressure and the Indirect type which are incorporated into special manifolds and are operated by spring pressure as the main line pressure decays. The former gives a rapid full pressure response, whilst the latter gives a slower output.

□ Volumetric

## Description

This is a positive displacement delivery system: Distributors deliver specific amounts of lubricant to the bearings. The surplus pump output is returned to the reservoir. This enables the number of points to be varied without major changes to the entire circuit.

Direct and Indirect distributors are available: the former operate as the main line pressure increases and they can be fitted either into a manifold or directly into bearing housings: the latter operate as the main line pressure reduces, delivery to the bearing is by spring.

A pressure check is sufficient to ensure that all points are lubricated.  
Lubricants: Oils up to 1500 cSt/40°C viscosity and up to '00' soft grease.

### Fully Automatic Lubrication System

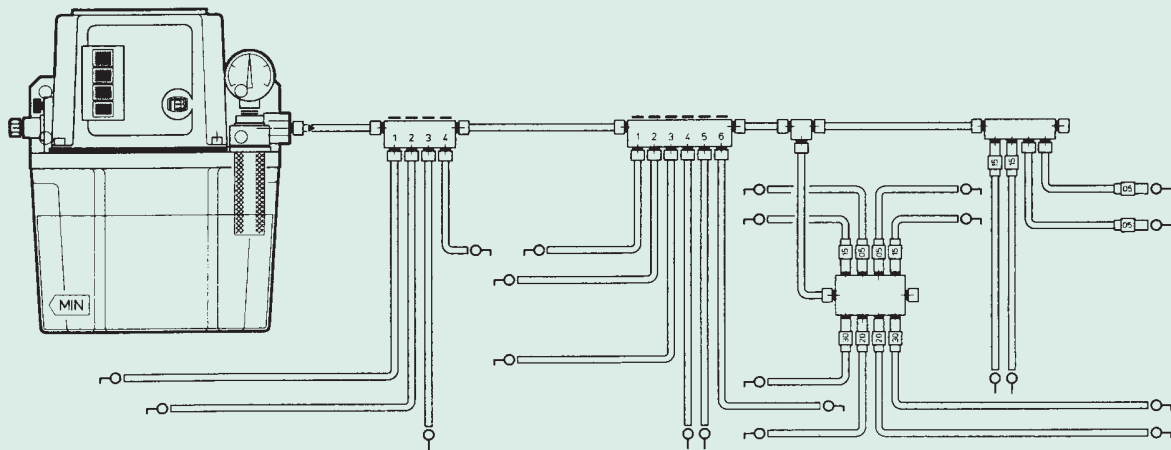

### Schematic

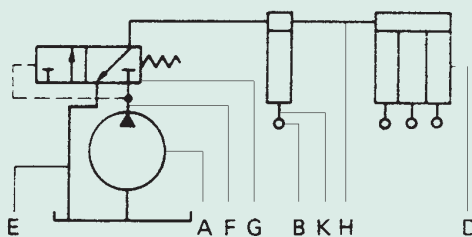

## Method of Operation

In the above illustration of a total loss single line volumetric system the pump (A) is intermittently operated, causing pressure to be generated via (F) in the main line (H). This high pressure forces measured quantities of lubricant out of metering device (Direct Action) (D) through feed line (K) and on to lubrication point (B).

The pump pressure is automatically released at relief valve (G) and main line pressure is decayed back to reservoir via relief line (E). During this period the pistons in the metering devices recover their positions in readiness for the next lubrication cycle.

All Adams direct and indirect volumetric single line systems perform as outlined in BS 4807 and ISO 5170.

## Combined Motorised Pump & Control Timer - For Oil up to 1500 cSt/40°C

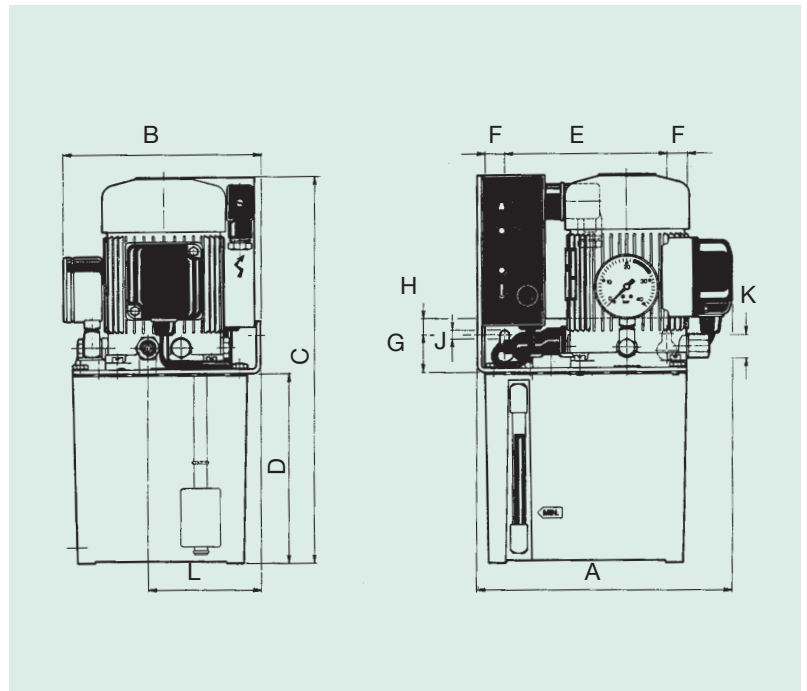

Part No	Res.	Voltage	Rating	A	B	C	D	E	F	G	H	J	K	L
LV 67182	2 Lt Alum	110V 50Hz	70 Watt			296	146							
LV 67288	2.7 Lt Plastic	Single Phase		196	145	305	155	125	15	28	12	7		
LV 10701	8 Lt Steel			360	210	330	180	330	15	75	40	8.5	M12 x 1	85
LV 67282	2 Lt Alum	230V 50Hz	Intermittent			296	146							
LV 67292	2.7 Lt Plastic	Single Phase		196	145	305	155	125	15	28	12	7		
LV 10702	8 Lt Steel			360	210	330	180	330	15	75	40	8.5		

**Note:** Outlet Connectors are available as follows:-

- For 6mm Ø tube use Adaptor LV 90026 with Washer LV 91825 Tube Nut LV 90460 & Sleeve LV 90560
- For 8mm Ø tube use Tube Nut LV 90480 & Sleeve LV 90682
- For 1/4 BSP Female (to screw in Filter LV 10009) use Adaptor LV 90044 with Washer LV 91825

### SPECIFICATION

- Motor Rating - 70 Watt
- Pump Lubricant Output - 360 cc/min
- Delivery Pressure - 22-28 bar
- Interval Range - Variable 2 min to 8 hours
- Pumping Range - Variable 0 to 60 seconds
- Complete with Low Level & Line Pressure Switches, Manual Override Button.

Four L.E.D. Indicators monitoring system condition.

Control Timer will give a Lubrication Cycle on initial Switch 'On' and will repeat at the preset intervals.

Reservoir Oil Levels and System Oil Pressure are continuously monitored and confirmed by Visual Indicator.

'Voltage Free' connections for Remote Alarms and the facility to stop the machine are also provided.

Anti-vibration mountings for use with above units are shown on Page 78.

## Combined Motorised Pump & Control Timer

For Oil up to 1500° cSt/40°C

Developed for single line centralized lubrication systems with positive displacement distributors, to provide manual or automatic cyclic lubrication. Three types are available (see table).

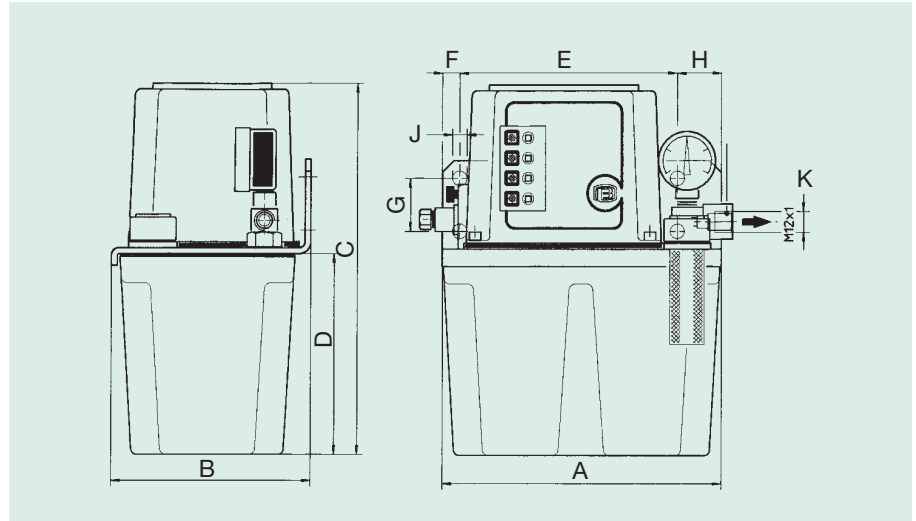

Part No.	Voltage	Rating	A	B	C	D	E	F	G	H	J	K	Leds	Control Type
LV 65054/110	110	0.1 kW 1.5A	205	136	273	150	130	10	50	17	7	M 12x1	0	A
LV 65062/110													2	B
LV 65066/110													4	C
LV 65054/230	230	0.1 kW 0.75A											0	A
LV 65062/230													2	B
LV 65066/230													4	C

**Note:** Outlet connections are available as follows:-

For 6mm Ø tube use Adaptor LV 90026 with Washer LV 91809, Tube Nut LV 90460 and Sleeve LV 90560

For 8mm Ø tube use Tube Nut LV 90480 and Sleeve LV 90682

For 1/4 BSP Female (To screw in Filter LV 10009) use Adaptor LV 90044 with Washer LV 91809

### Motor pump assembly specification:

- gear pump: 180 cc/min output
- electric motor 110 Volt 50/60Hz or 230 Volt 50/60Hz Single Phase - State which required
- delivery pressure 22-28 bar
- plastic (transparent) reservoir capacity: 3 litre

**TYPE A** Manual operation: Push button on side of unit until max. pressure is reached, release button for at least 1 minute, max. pump operation time 4 mins.

**TYPE B** Automatic with control timer: Set "dip" switches to required Interval time: 2.5 / 5 / 10 / 20 / 40 / 80 mins. These switches can be used together to give Interval times from 2.5 mins. to 157.5 mins. Pump running time is pre-set at 30 secs. Green LED for Interval. Yellow LED for Pump operating.

**TYPE C** Automatic with monitoring (Time or Cycles) : Select Interval time or M/c cycle count with bridging link and rotate cam disc to set required value. i.e. Time - 1 min to 37 hrs. Counter - 1 to 2048 cycles. Lube time is dependent on max. pressure build up. Pump stops 15 secs. after pressure switch signal is reached. Green LED for Interval, Yellow LED for Pump operating, Red LED's for Low oil level and Low oil pressure.

## Motorised Pumps and Reservoirs - Type GM, GR & GQG For Oil & Fluid Grease

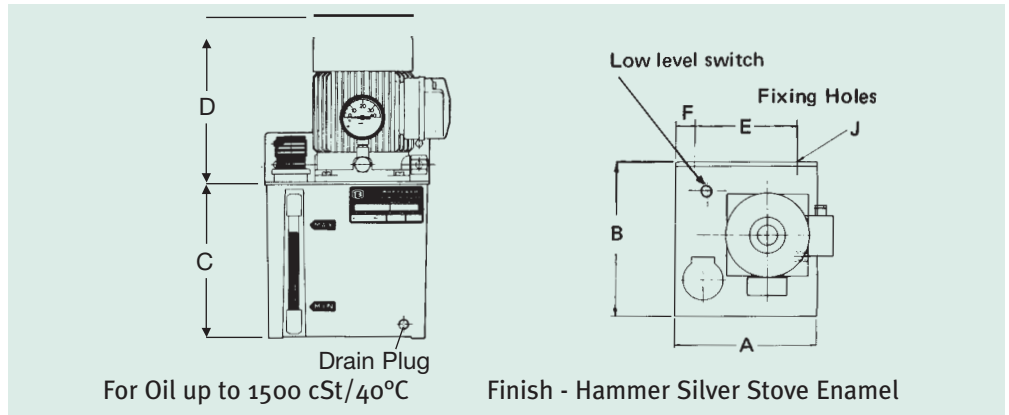

Part No. / Voltage	Rating	Output /Minute	Reservoir	Delivery Pressure	A	B	C	D	E	F	J	K
LV 63121 230 - 400V 50Hz 3 Phase	70W	0.38 litre	2 litre Alum.	22-28 bar	155	142	146	146	125	15	8.5	M12 x1
LV 63131/110 110V50Hz Single Phase	70W	0.38 litre										
LV 63131/230 230V50Hz Single Phase	Intermittent	0.38 litre	2.7 litre Plastic	22-28 bar	155	142	152	146	125	15	8.5	M12 x1
LV 63569 230 - 400V 50Hz 3 Phase	70W	0.38 litre										
LV 63590/110 110V50Hz Single Phase	70W	0.38 litre	3 kg Plastic	30-35 bar	207	136	150	146	130		6.5	M12x1
LV 63590/230 230V50Hz Single Phase	Intermittent	0.38 litre										
<b>For Grease '00' and '000' NLGI</b>												
LV 64013 230 - 400V 50Hz 3 Phase	70W	0.18 litre	6 kg Plastic	30-35 bar	271	200	200	146	241		8.0	M12x1
LV 64017 230 - 400V 50Hz 3 Phase	70W	0.18 litre	3 kg Plastic	30-35 bar	207	136	150	146	130		6.5	M12x1

Low Level Float Switches are Fitted as Standard

Overpressure Relief and Residual Pressure Release Valves are Fitted

## Motorised Pumps and Reservoirs

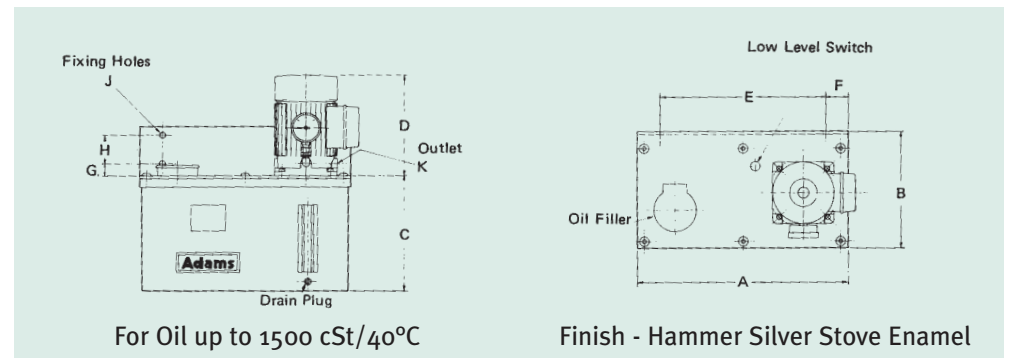

Part No. / Voltage	Rating	Output /Minute	Reservoir	Delivery Pressure	A	B	C	D	E	F	G	H	J	K
LV 61498 230 - 400V 50Hz 3 Phase	70W	0.38 litre	5 litre Alum.	22-28bar	248	174	155	146	218	15	20	40	8.5	M12x1
LV 63134/110 110V 50Hz Single Phase	70W													
LV 63134/230 230V 50Hz Single Phase	Intermittent	0.38 litre	8 litre Steel	22-28bar	363	180	170	146	330	15	15	40	8.5	M12x1
LV 63127 230 - 400V 50Hz 3 Phase	70W	0.38 litre												
LV 63137/110 110V 50Hz Single Phase	70W	0.38 litre												
LV 63137/230 230V 50Hz Single Phase	Intermittent													

Low Level Float Switches are Fitted as Standard

Overpressure Relief and Residual Pressure Release Valves are Fitted

## Motorised Pumps - For Oil up to 1500 cSt/40°C

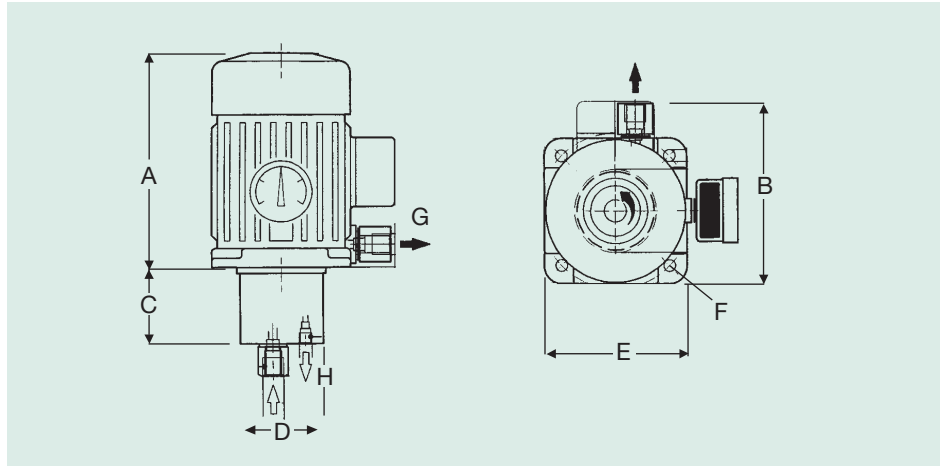

Part No.	Voltage	Rating	Output /Minute	Delivery Pressure	A	B	C	D	E	F	G OUTLET	H INLET
LV 10237	230 - 400 Volts 50Hz 3 Phase	70W Intermittent	0.38 litre	22-28 bar	146	130	62	59	90	5.5 dia holes on 100 PCD	M12x1	8mm Ø tube
LV 10286	110 Volts 50 Hz Single Phase	70W Intermittent	0.38 litre									
LV 10346	230 Volts 50 Hz Single Phase	70W Intermittent	0.38 litre									

Ported Overpressure Relief/Residual Release Valve Fitted

**MOUNT VERTICALLY ONLY**

## Pneumatic Pumps - For Oil up to 1500 cSt/40°C

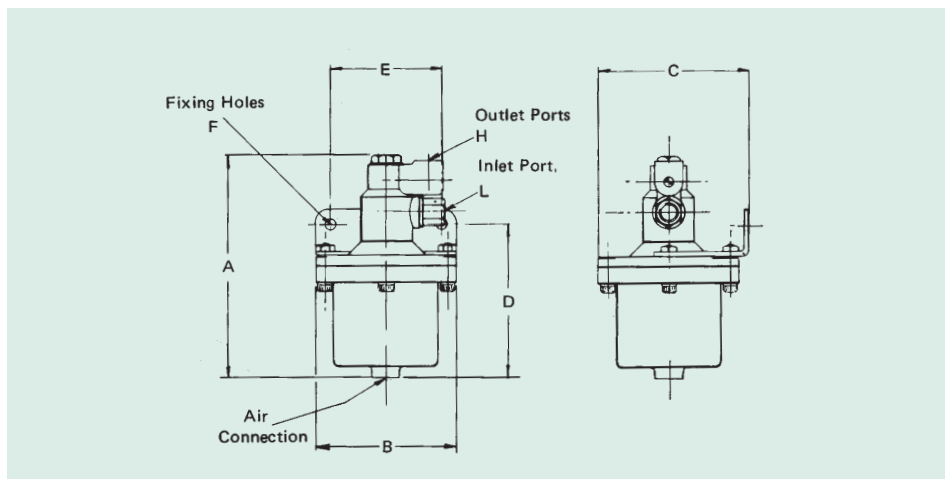

Part No.	Output /Stroke	Airline Pressure Min	Max	A	B	C	D	E	F	G	H	L
LV 10000	16cc	4.5 bar	6 bar	152.4	95.3	100	103.2	76.2	7.14	1/4 BSP	1/8 BSP	1/4 BSP
LV 10171	30cc	4.5 bar	6 bar	167	106	-	-	-	-	M10x1	M12x1	M16x1.5

Ratio - Oil pressure output/airline pressure 5:1

Ported residual pressure release valve

## Pneumatic Pump and Reservoir - For Oil up to 1500 cSt/40°C

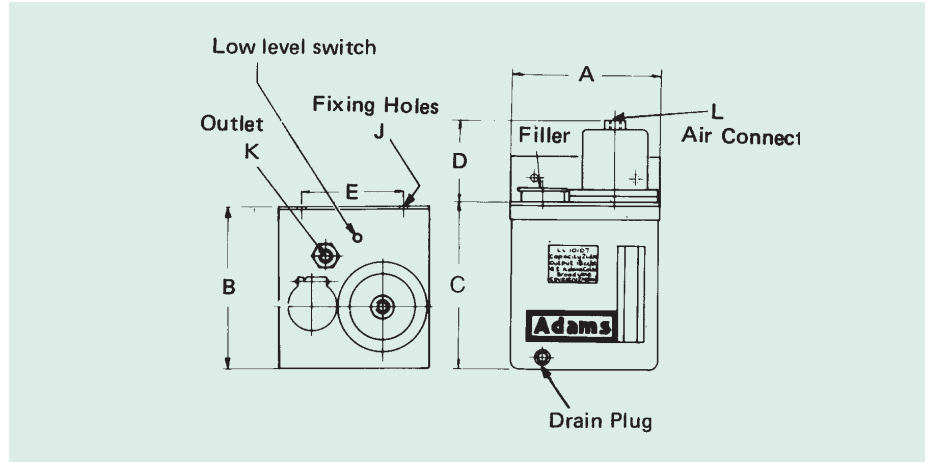

Part No.	Reservoir	Output /Stroke	Airline Pressure Min	Airline Pressure Max	A	B	C	D	E	F	G	H	J	K	L
LV 10600 FS	2 Lt Alum	16cc	4.5 bar	6 bar	155	142	146	80	125	-	-	-	-	1/4 BSP	1/4 BSP
LV 10601 FS	2.7 Lt Plastic						152								

Low Level Switch Fitted as Standard  
Residual pressure release valve fitted

Finish - Hammer Silver Stove Enamel  
Ratio - oil pressure output/airline pressure 5:1

## Pneumatic Pumps and Reservoirs - For Oil up to 1500 cSt/40°C

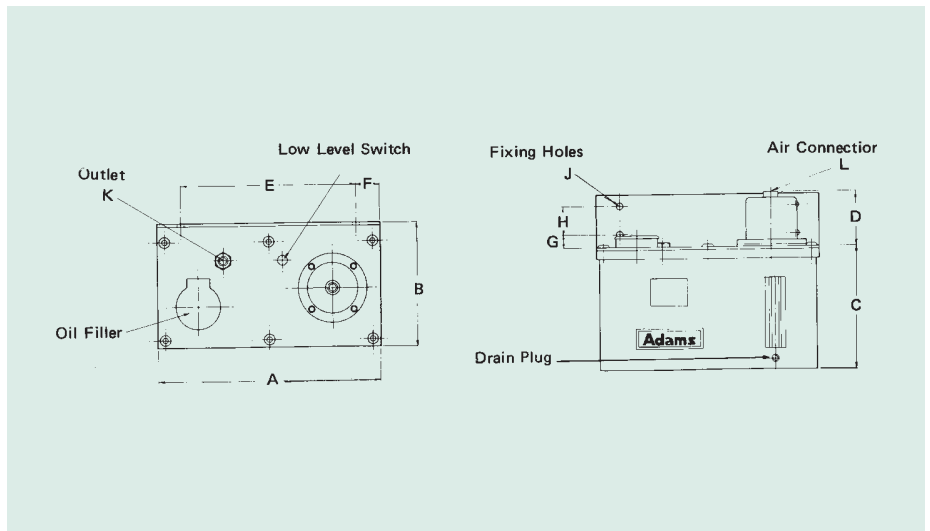

Part No.	Reservoir	Output /Stroke	Airline Pressure Min	Airline Pressure Max	A	B	C	D	E	F	G	H	J	K	L					
LV 10602 FS	5Lt Alum	16cc	4.5 bar	6 bar	248	174	155	80	218	15	15	40	8.5	1/4 BSP	1/4 BSP					
LV 10603 FS	5Lt Alum	30cc													363	190	180	335	15	M10x1
LV 10605 FS	8Lt Steel																			

Low Level Switch Fitted as Standard  
Residual pressure release valve fitted

Finish - Hammer Silver Stove Enamel  
Ratio - oil pressure output/airline pressure 5:1

## Manual Pump and Reservoir -

For Oil up to 1500 cSt/40°C

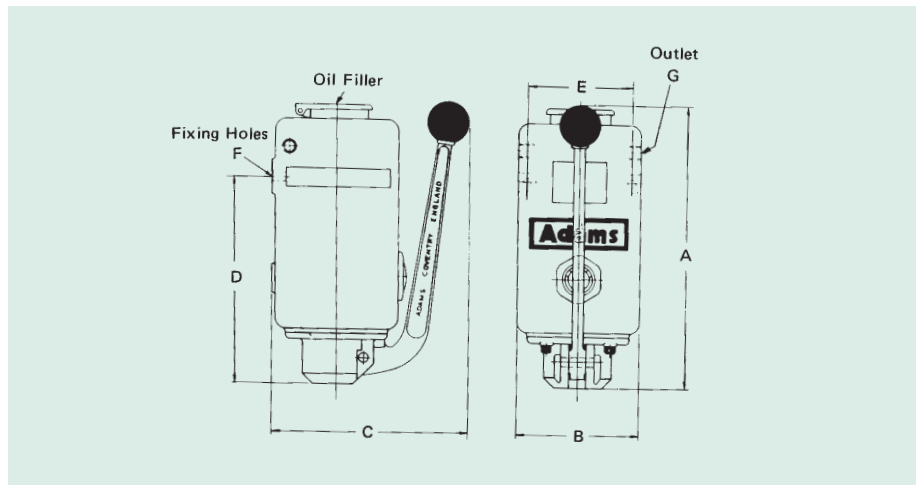

Part No.	Capacity	Output/ Stroke	Internal Relief	A	B	C		D	E	F	G
						Open	Closed				
LV 10310	1 litre	16cc	22-28 bar	272	114	324	184	194	98.42	7.14	1/4 BSP

Reservoir - Cast Aluminium

Finish - Hammer Silver Stove Enamel

## Pneumatic Pump and Reservoir -

For Oil up to 1500 cSt/40°C

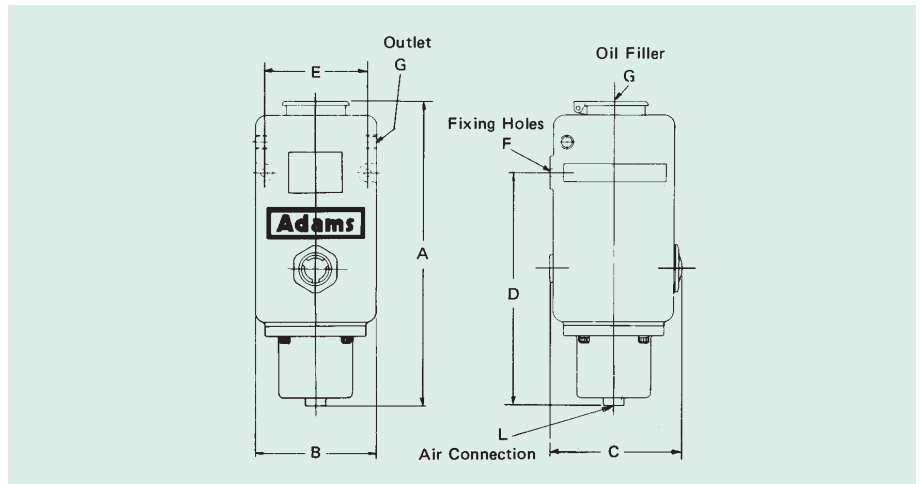

Part No.	Capacity	Output/ Stroke	Airline Pressure		A	B	C	D	E	F	G	L
			Min	Max								
LV 10311	1 litre	16cc	4.5 bar	6 bar	294	114	122	217	98.42	7.14	1/4 BSP	1/4 BSP

Ratio - oil pressure output/airline pressure 5:1  
Residual pressure release valve fitted

Reservoir - Cast Aluminium  
Finish - Hammer Silver Stove Enamel

## Direct Metering Valves - For Precise Amounts of Lubricant

Part No.	Output/ Stroke cc	Operating Pressure	A	B a/f	C Taper	D Taper
LV 50785	0.02	22-28 bar	32	12	1/8 BSP	1/8 BSP
LV 50786	0.05					
LV 50787	0.10					
LV 50788	0.15		40			
LV 52920	0.20					
LV 50789	0.30					
LV 52950	0.50					
LV 51144	0.40	22-28 bar	44	17	1/8 BSP	1/4 BSP
LV 51145	0.70		51			
LV 51146	1.00					

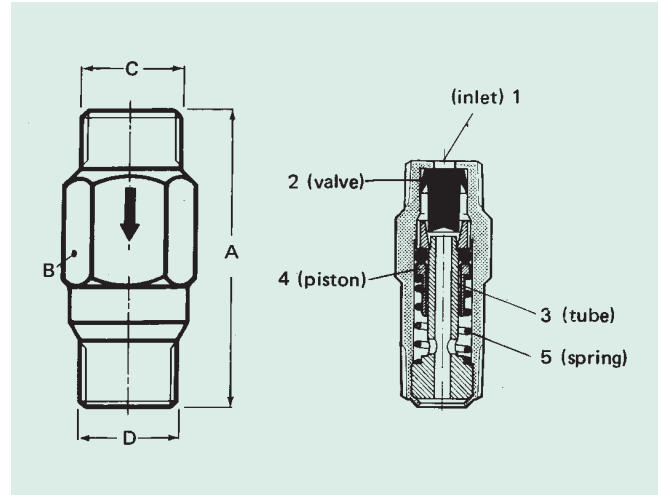

When the lubrication pump operates pressure is built up in the main supply line and oil enters through inlet port (1) forcing valve (2) off its seat and blocking the outlet tube (3). The outer lips of valve (2) collapse allowing the oil to push piston (4) forward, compress spring (5) and eject the metered volume of oil already stored in the chamber in front of piston (4) from the previous operation.

On decompression of the main oil supply line the spring expands causing the volume of oil at the rear of piston (4) to re-seat valve (2) opening outlet tube (3) allowing the trapped oil to transfer into the chamber in front of piston (4) in readiness for the next operation.

## Mini-Kappa Meter Valves - For Lower Cost Systems

### Bearing Type MKP

Part No.	Output/ Stroke cc	Operating Pressure	A	B a/f	C	D Taper
LV 53096	0.03	22-28 bar	26	11	M9x1	1/8 BSP
LV 53097	0.05					
LV 53098	0.10					
LV 53099	0.15					

### Manifold Type MKD

LV 53100	0.03	22-28 bar	26	11	1/8 BSP	M9x1
LV 53101	0.05					
LV 53102	0.10					
LV 53103	0.15					

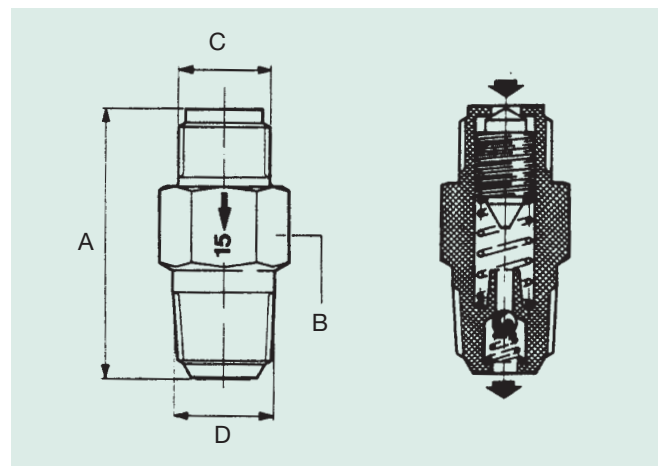

For Valve Heads and Manifolds to suit Mini - Kappa Range - See Pages 16 & 17.

When using MKD Type please use Washer LV 92744 on Manifold Seating. Material - Steel Body Finish - zinc plate

The pressure of the oil supplied by the pump causes the meter valve pistons to move forward, so discharging their measured amounts to the lubrication points. At the end of the stroke, a conical valve on the end of the piston seals off the outlet preventing any further discharge. As supply pressure decays, the spring returns the piston to its original position ready for the next cycle, oil being transferred via spiral grooves in the piston. The non-return valve prevents leakage between shots and thus ensures that the system is always primed.

## Direct Metering Valve Heads - Supplied Complete with Nuts & Sleeves

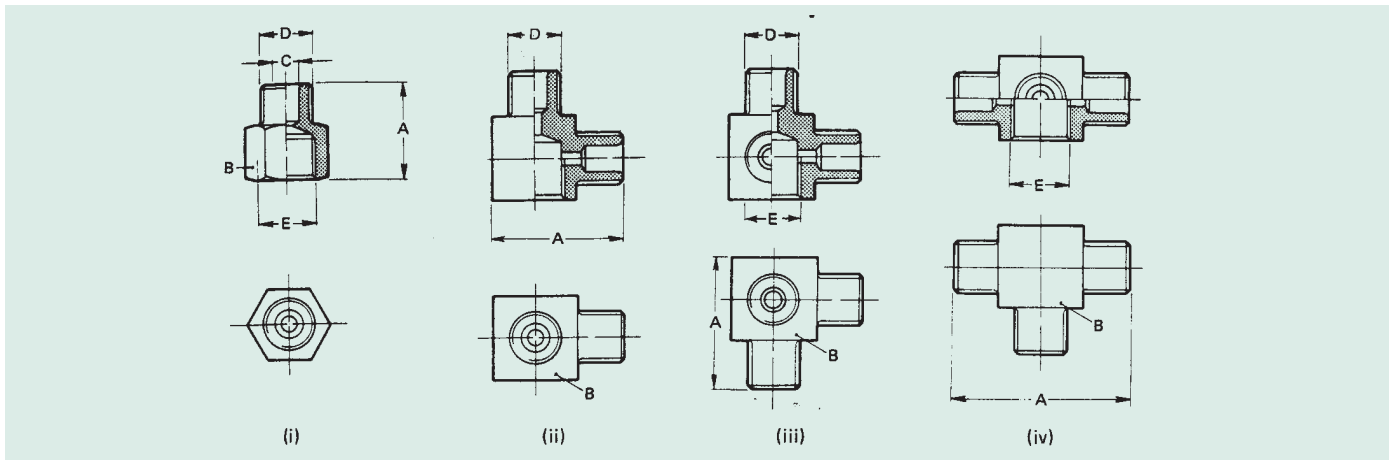

Part No.	Type	A	B a/f	C	D	E	
LV 10450	i	15	12	4mm $\varnothing$ tube	M8 x 1	1/8 BSP	
LV 10451	v	20	13				
LV 10452	vii	28					
LV 10453	i	16		6mm $\varnothing$ tube	M10 x 1		
LV 10454	v	20					
LV 10455	ii						
LV 10456	vi						
LV 10457	vii			28	21		28
LV 10458	iii						
LV 10459	iv	28		17	4mm $\varnothing$ tube		M8 x 1
LV 10460	viii				6mm $\varnothing$ tube	M10 x 1	
LV 10480	i	23	11	4mm $\varnothing$ tube	5/16 UNF	M9 x 1	
LV 10481		16					
LV 92888	v	20	12.5				
LV 92890	vii	28					
LV 92891	vi	20					
LV 92889	ii						
LV 92892	iii						
LV 92895	iv						
LV 92894	iv	28					viii
LV 92896	viii						

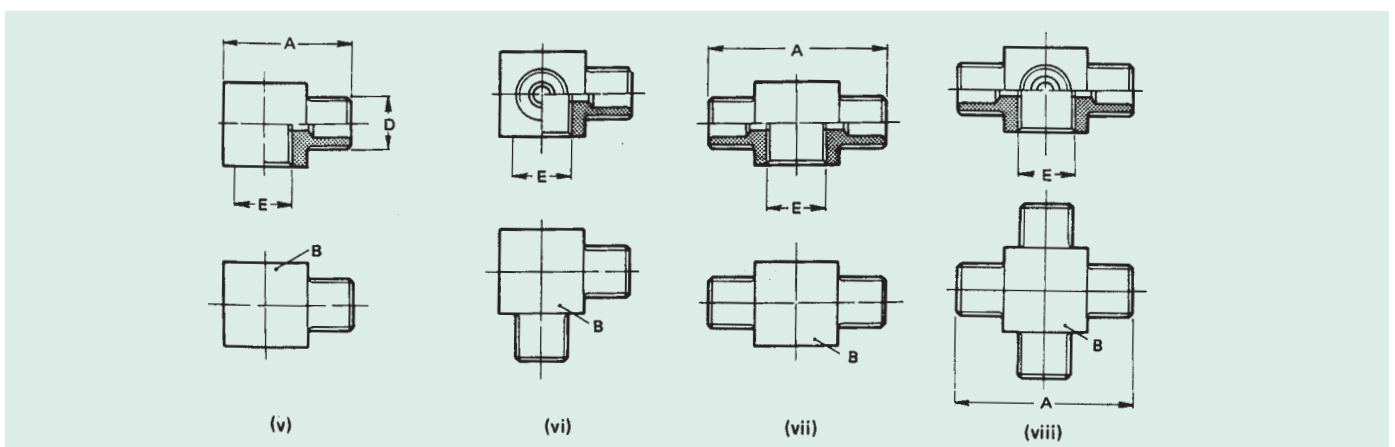

## Manifolds for Direct Metering Valves

### Single Sided

Part No.	No. Of Outlets	A	B
LV 95282	1	20	40
LV 95283	2	41	61
LV 95284	3	62	82
LV 95285	4	83	103
LV 95286	5	104	124
LV 95287	6	125	145
LV 95288	7	146	166
LV 95289	8	167	187

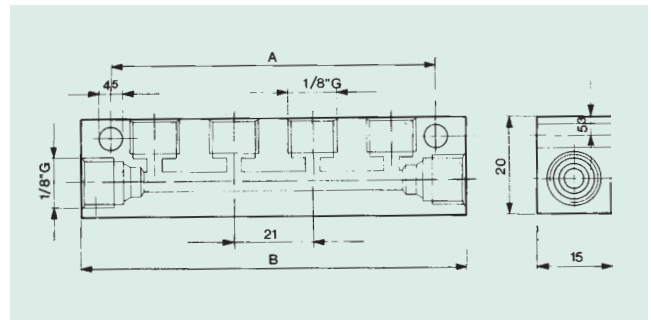

### Double Sided

Part No.	No. Of Outlets	A	B
LV 95290	2	20	40
LV 95291	4	41	61
LV 95292	6	62	82
LV 95293	8	83	103
LV 95294	10	104	124
LV 95295	12	125	145

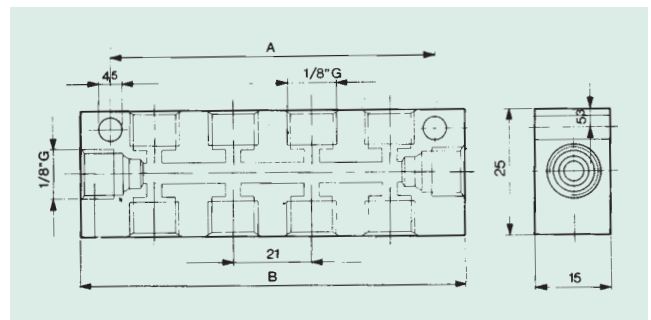

### Straight Adaptor

Part No.	A	B	C a/f	D Taper	E
LV 20130	16	10	17	1/8 BSP	1/4 BSP

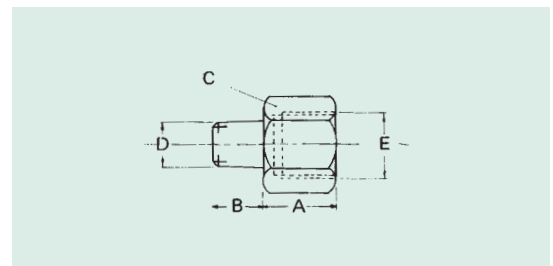

### Angle Adaptor

Part No.	Angle	A	B	C a/f	D	E
LV 10461	90°	24	8	12	1/8	1/8 BSP
LV 10484		30		20	BSP	1/4 BSP
LV 10462	45°	22	9	12	1/8	1/8 BSP
LV 10485		30		20	BSP	1/4 BSP

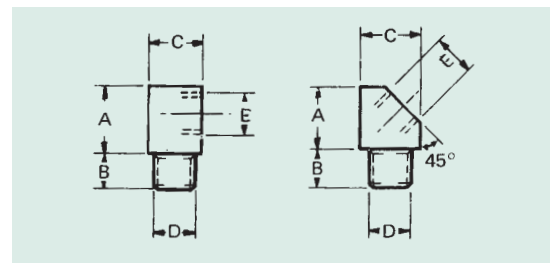

Material - Steel

Finish - Zinc plate

For further Range of Adaptors and Connectors  
Please see the Fittings Section of Catalogue

## Indirect Volumetric Distributors - US, USM (Non Visual)

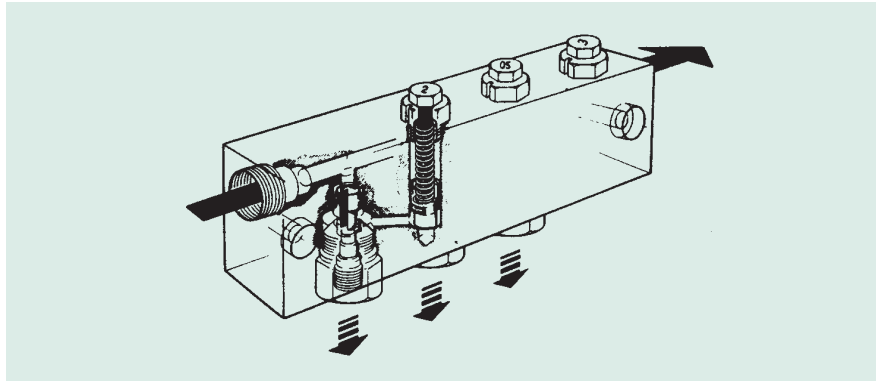

### Features

US and USM series volumetric distributors are designed for indirect lubrication.

i.e. delivery to the bearing is by spring displacement after discharge of the pump pressure.

Metering screws at each outlet are used for delivery of predetermined amounts of lubricant, ranging from 0.05 - 1.0 cc/stroke. Each screwhead is marked with a number showing the volume of discharge.

Compression sleeves and cap screws acc. to DIN 2367 are provided for the supply lines and outlet ports.

**Operating Pressure** - 22-28 bar

**Lubricant** - Oil, viscosity 15-1500 cSt/40°C.

### Model US

Part No.	No. of Outlets	A	B	C
LV 50012	1	36	54	24
LV 50013	2	53		41
LV 50014	3	70		58
LV 50015	4	87		75
LV 50016	5	104		92
LV 50017	6	121		109

### Model USM

Part No.	No. of Outlets	A	B	C
LV 50036	1	36	44.5	24
LV 50037	2	53		41
LV 50038	3	70		58
LV 50039	4	87		75
LV 50040	5	104		92
LV 50041	6	121		109

### USM - Metering Screws

Part No.	Model	Output	Marked
LV 50105	MD05	0.05cc	05
LV 50106	MD1	0.1cc	1
LV 50107	MD2	0.2cc	2
LV 50108	MD3	0.3cc	3
LV 50109	MDX	NIL	X

### US - Metering Screws

Part No.	Model	Output	Marked
LV 50099	SD1	0.1cc	1
LV 50100	SD2	0.2cc	2
LV 50101	SD4	0.4cc	4
LV 50102	SD7	0.7cc	7
LV 50104	SDX	NIL	X

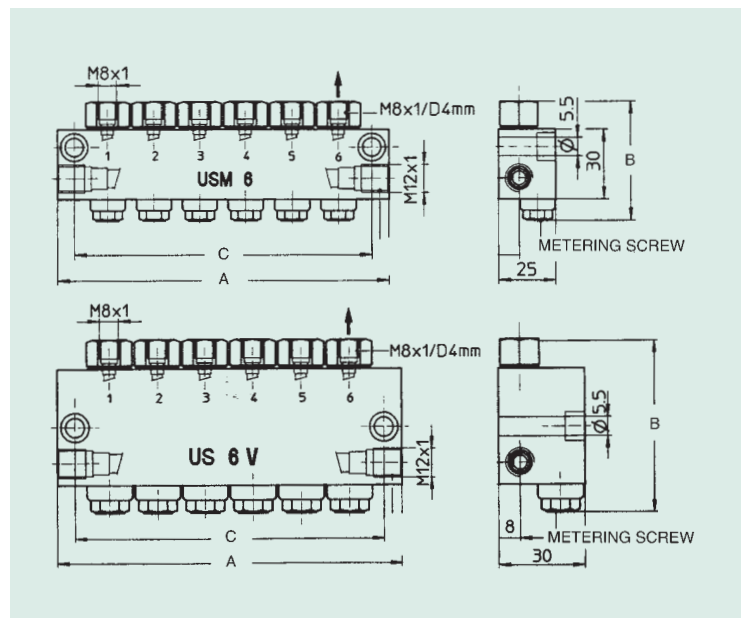

## Indirect Volumetric Air/Oil Distributors - USPP (Non Visual)

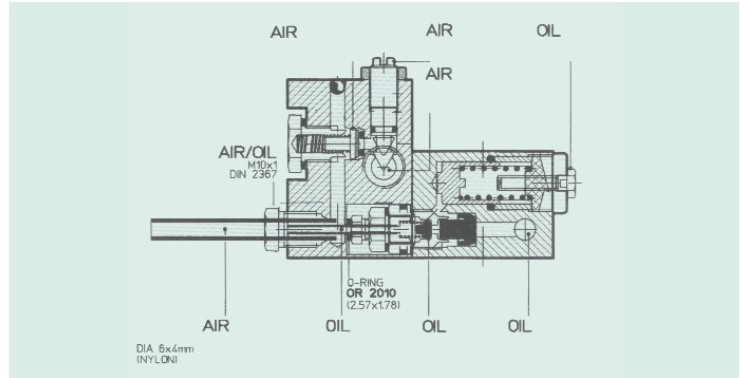

### Features

The USPP series is a minimal air/oil indirect volumetric lubrication distributor designed to meet the demands of modern machine tools. A predetermined volume of oil is metered into a current of air, which breaks the oil into particles and transports the air/oil mix to the lubrication point. Therefore the lubrication point is supplied with continuous lubricated air.

**Operating Pressure** - 22-28 bar

**Lubricant** - Mineral Oils, viscosity 20 to 220 cSt/40°C.

### Distributors

Part No.	No. of Outlets	A	B
LV 52521	1	24	36
LV 52522	2	41	53
LV 52523	3	58	70
LV 52524	4	75	87
LV 52525	5	92	104
LV 52526	6	109	121

### Metering Screws

Part No.	Output	Marked
LV 50099	0.1cc	1
LV 50100	0.2cc	2
LV 50101	0.4cc	4
LV 50102	0.7cc	7
LV 50104	Plug	X

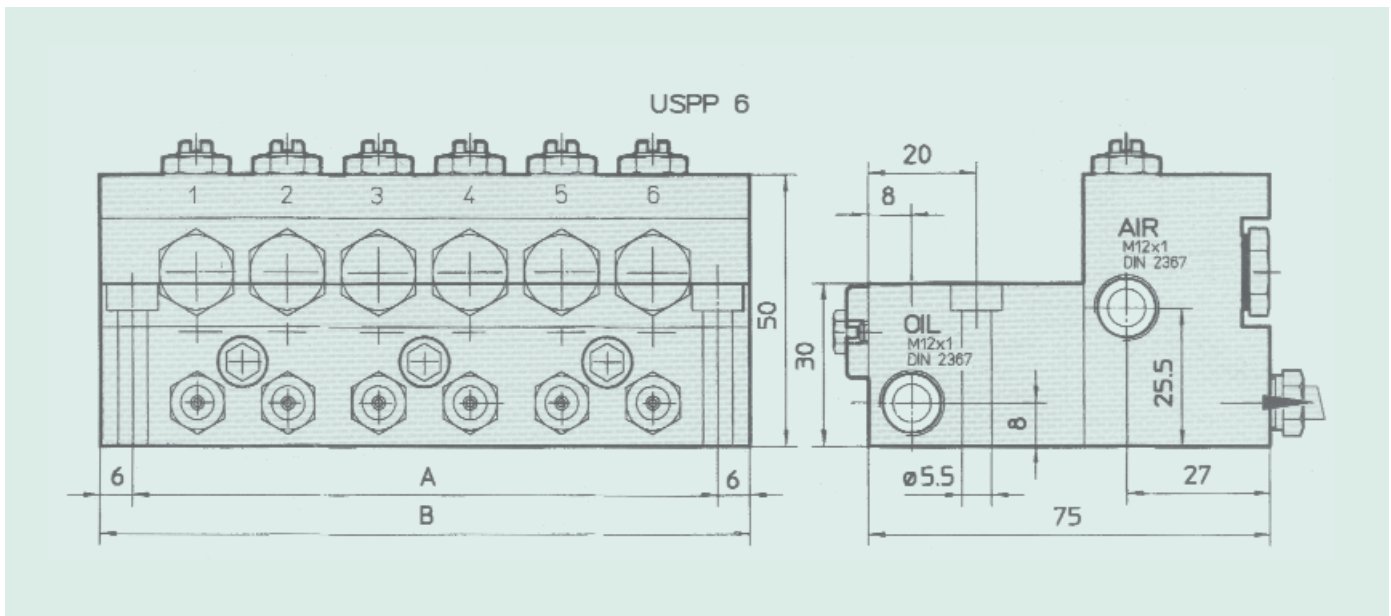

## Timers and Program Controllers

### Description

The program controller LV 70135-41 has been specially developed for use with lubrication systems. These programmers are available with either 110 Volt, 230 Volt single phase or 24 Volt DC supply.

The timer gives a pre-lube output signal as soon as power is switched on, thereafter alternating between intervals and pump running mode. Settings for 'Intervals' and 'Lubrication' are easily set by altering the dip switches, and coloured 'LED's' are provided for visual confirmation of performance.

A flashing green LED indicates the interval period,

A yellow LED indicates Pump Running in the case of electric pump, or else Power On in the case of a solenoid operated pneumatic pump.

There are 2 red LED's, a flashing LED to indicate a loss of pressure or a fault condition and a steady red light to show a low oil level situation.

A fault relay can be used to stop the machine or provide a signal to a lamp, klaxon etc. The programme controller can be supplied in a plastic enclosure complete with lockable door and mains isolating switch.

Anti-Vibration mountings are recommended for use between the timer enclosure and the face of the machine-see P 78.

LV 70135-41



LV 10496

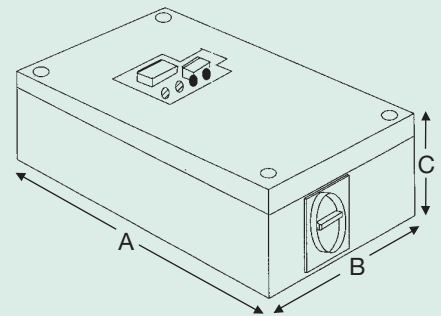

Part No.	Voltage	A	B	C	D	E
LV 70135	24 V DC	138	112	60	-	-
LV 70137	24 V 50/60 Hz					
LV 70139	110 V 50/60 Hz					
LV 70141	230 V 50/60 Hz					
LV 10496 (In Enclosure) State Voltage Req'd.	As Above	250	170	112	-	-
LVT 10780	24/48 V 50/60Hz AC/DC	90	70	42	21	32
LVT 10781	110/230 V 50/60Hz AC					

'Din Plug' programme timer LVT 10780 and LVT 10781, this programme timer can be used in conjunction with any solenoid valve fitted with cable plug to Din 43650 standard. Internally programmable via dip switches and potentiometers range 0.5secs to 10hours.

Two LED's display the mains voltage and valve status.

Can be used to control pneumatically operated oil and grease pumps.

### SPECIFICATION

Timing range: On: 0.5. sec to 10 hours Off. 0.5 sec to 10 hours

Switching load: 1.5A at 24-48V/50-60Hz and DC  
0.5A at 110-230V/50-60Hz

Power consumption: 1.0W max

Rating: IP 65

Working temperature: 0°C to +60°C

Material - POLYAMID BODY

Outlet: Connector pin standard to DIN 43 650

LVT TYPE

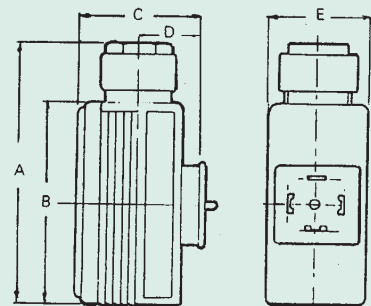

### Line Filters

Part No.	A	B	C&D	Micron Rating
LV 10009	88	18	1/4 BSP	53
LV 10029				250

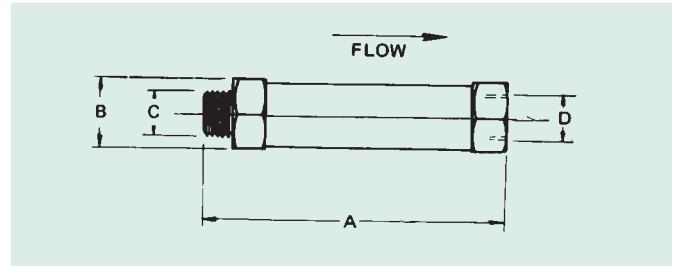

### Low Oil Level Switch

Part No.	A	B	C	D	E
LV 10465	150	30	45	35	M20 x 1.5
LV 10478	143				

Material: Float - plasticell Tube - brass

#### Operating Conditions

Temperature -40°C to +85°C

Minimum Specific Gravity - 0.58

#### Electrical Specifications

Max. contact rating - 20 Watts AC/DC

Max. amps - 1.5 AC/DC

Max. volts - 350 AC

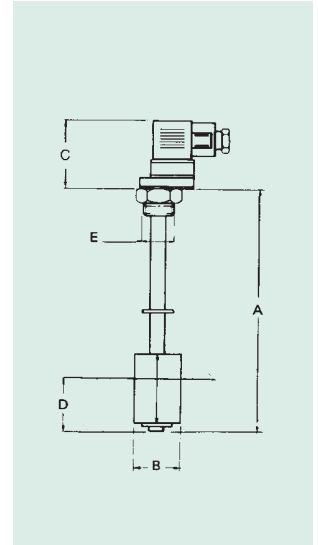

### Pressure Switch - with Din Plug to IP 65

Part No.	Adjustment Range Bar.	A	B	Thread
LV 10551	10-100	73	27A/F	1/4 BSP

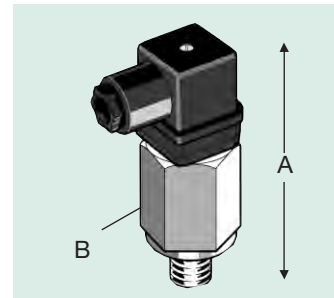

### Pressure Gauge

Part No.	Pressure Range	Diameter	Thread
LV 10408	0-40 bar	50	1/8 BSP



**Solenoid Valves**

Part No.	Main Ports	Operating Pressure	A	B	C	D
LV 10405	1/4 BSP	10 bar Max	92	73	50	78

**Power Consumption:**

	AC supply	DC supply
Inrush	20 VA	-
Hold	10 VA	9 Watts

**Please State Voltage:-**

12V DC	24V 50/60 Hz
24V DC	48V 50/60 Hz
	110V 50/60 Hz
	230V 50/60 Hz

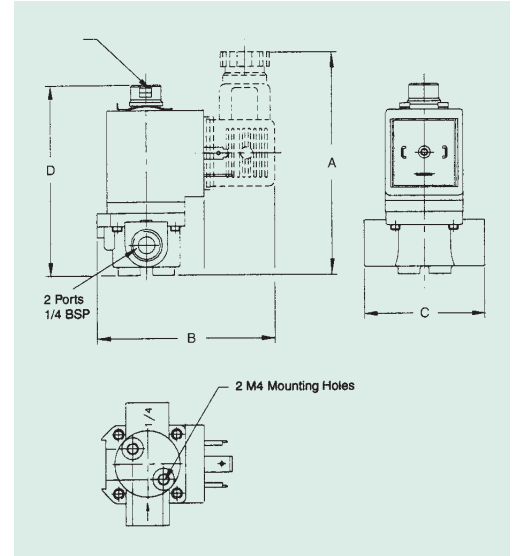

**Flexible Hoses - SAE 100R3**

FLS 3/16 - 1/4 - 3/8 Bore  
Please State Length

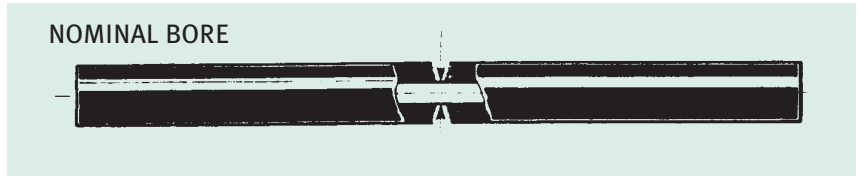

**Hose End Connections**

Hose Bore	Part No.	A ∅	B	C	A/F1	A/F2
3/16	LV 90490	4	22	51	9	15
	LV 90491	6	26	55		
1/4	LV 91269	8	30	66	12	17
	LV 91268	10	36	72		
3/8	LV 90489	12	38	76	17	24

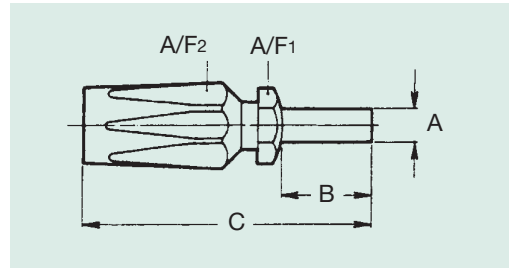

**Swivel Joints - Max pressure 5 bar, max 500 rpm**

Part No.	Tube ∅	A Taper	B Tube Nut	C	D	E A/F	F
LV 90220	4	1/4 BSP	M8 x 1	8	38	12	28
LV 90222		M10 x 1					
LV 90224		1/8 BSP					
LV 90228	6	M10 x 1	M10 x 1	8	38	12	28
LV 90230		1/8 BSP					

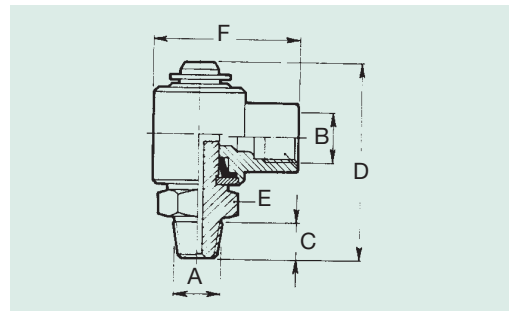

**Swivel Joints 90° - Max pressure 100 bar, max 100 rpm**

Part No.	A Taper	B Tube Nut	C	D	E A/F
LV 90250	1/8 BSP	1/8 BSP	10	31	12
LV 90252		M10 x 1			

