

Adams



Spray lubrication is a means of lubricating moving machine parts using atomised oil or grease. A stream of compressed air delivers a metered quantity of the required lubricant to the point of application.

Atomisation of the lubricant is obtained through a range of spraying devices, fitted with wide or narrow jet nozzles.

Lubricants: Oils up to 3000 cSt. viscosity @ 40 °C,
Greases up to Grade 2 (NLGI)

□ Spray Lubrication

Description

Various combinations of lubrication pumps, metering devices and air atomising valves can be used to provide efficient spray lubrication for the majority of machine tool requirements. Almost all of the oil and grease pumps found in this catalogue can be used as the prime mover of the lubricant, and by using either the SPR 01 spraying nozzle (for oil), or the SPR 02 nozzle (for grease), a simple and reliable system can be achieved. These spraying nozzles are provided with automatic closure of compressed air ports as lubricant delivery ceases. This means that circuits shut down after atomising, causing compressed air consumption to cease.

The spray nozzles can be located in one or more points of a centralized lubrication system and may be combined with a pump or metering valves, which will give them a metered lubricant amount to be atomised. A circular jet pattern approx. 70-98 mm dia. is then formed when the target distance is 300-450 mm.

A specialised microlubrication air/oil system for machine tooling protection has been introduced to the range - LUBROSTAR. This system provides a minimum amount of oil in order to give a much cleaner work area, whilst still giving improved protection of tooling.

Schematic

Showing 2 outlet motorised pump feeding 2 spray nozzles. Compressed air supply is serviced by filter, solenoid, pressure switch and regulator before passing via distributor manifold to spray nozzles. An optional pressure monitor is shown on the pump outlet pipelines.

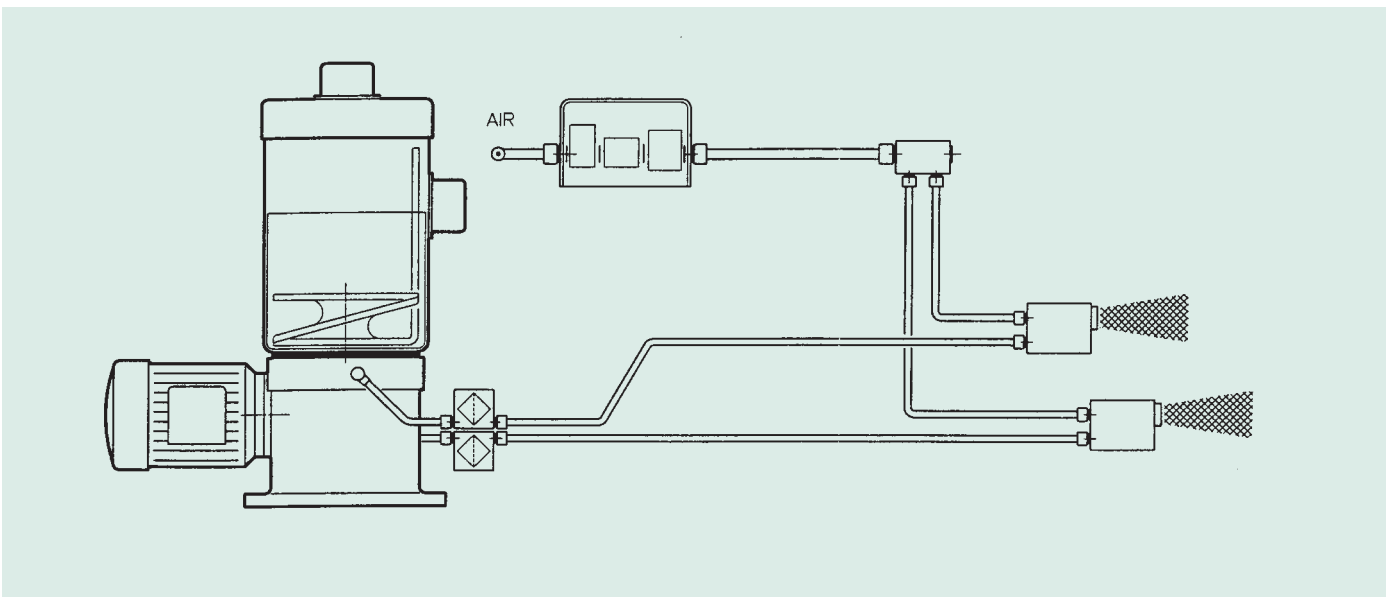

Spray Nozzles

SPR01 For Oil

SPR02 For Grease

Narrow Angle Jet Pattern

Output - 20 ccs/Min for oil

12 gm/Min for grease

Lubricant pressure - 20 to 100 bar

Compressed Air Pressure - 3 to 6 bar

Automatic air closure

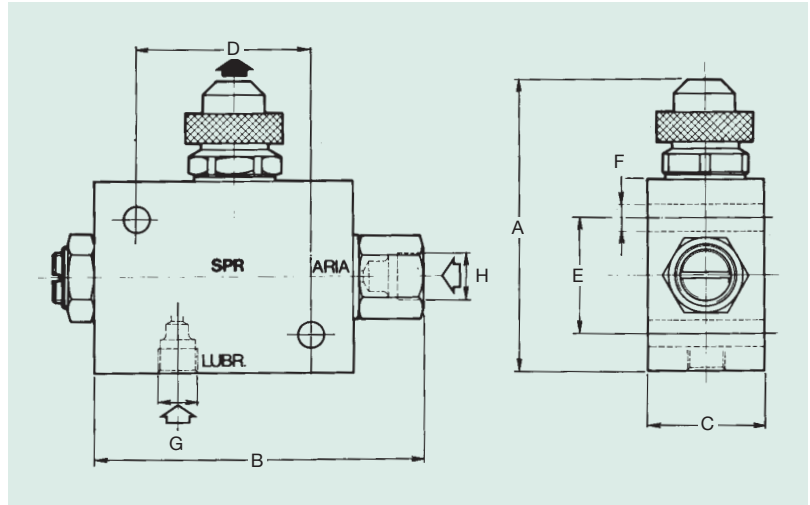

BSD 68 For oil or grease

Wide angle Jet Nozzle

Output - 30 grms/Min

Lubricant Pressure - 20 to 120 bar

Compressed Air Pressure - 3 to 6 bar

Not fitted with automatic air closure.

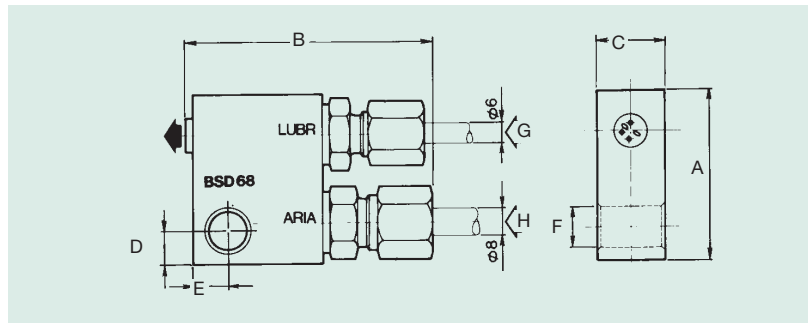

Part No.	Type	A	B	C	D	E	F	G	H
LV 52159	SPR01	76	85	30	45	30	7	M10x1	M12x1
LV 52160	SPR02								
LV 52161	BSD68	50	72	20	10	10	12	Ø 6	Ø 8

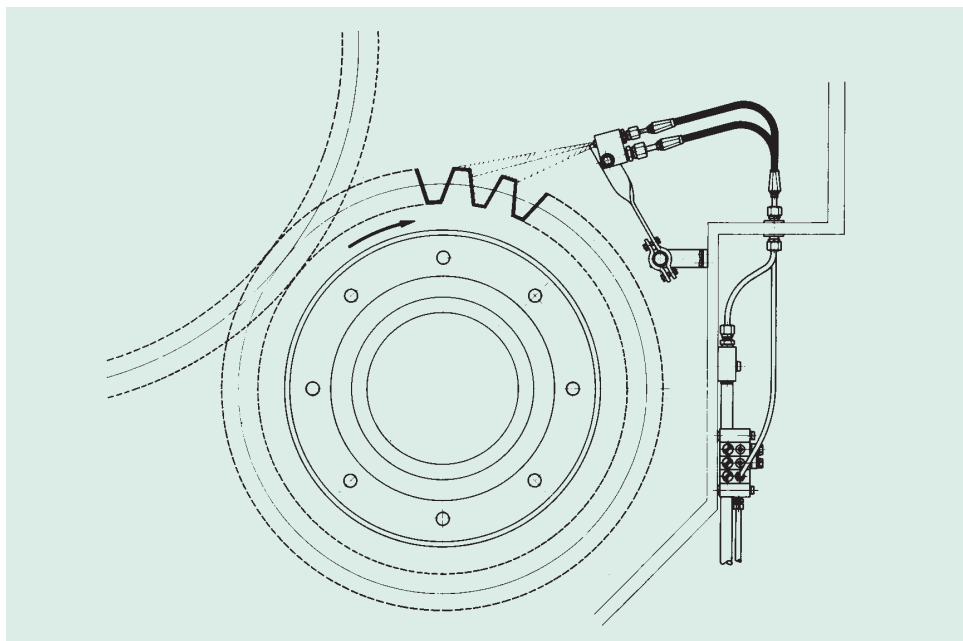

Example of Grease Spraying of Gears using BSD 68 Nozzle and Progressive Grease System.

Lubrostar

Industrial needs have promoted a new technology **microlubrication and cooling** which is proving highly successful in the field of metal cutting. The new generation machine tools, with their superior performance, the availability of materials made of ceramics coated with nitrided titanium and aluminium or of monocrystalline diamonds, together with the need for environmental protection has brought about a radical review of this process.

Small amounts of lubricant conveyed by a low pressure air stream and directed to the contact area between the tool and the material have proved very effective. This is achieved by the use of volumetric micro pumps dispensing oil via a capillary tube to a nozzle. A further coaxial tube supplies low pressure air to the nozzle which breaks the two into micro particles. These two elements are delivered to the contact area without causing pollution, combining oil lubrication with cooling provided by low pressure air.

Parts List

1. Watertight ABS enclosure - coloured Grey with transparent door. IP 65 protection
2. Plastic oil tank fitted with filling cap and filter.
3. Supplied with low level switch (NO)
4. 1/4 BSP Compressed air line filter (5 mesh gauze)
5. Solenoid operated On/Off valve for air
6. Air pressure regulator
7. Air pressure gauge, 0. to 12 bar.
8. Adjustable Pulse generator range:- 3 cycles per second to 1 cycle per minute
9. Air operated micro pump:- range 3 to 30mm³
10. Manifold for Air/Oil coaxial tubes
11. Outlet connectors for Air/Oil tubes
12. Air exhaust drain-off valve

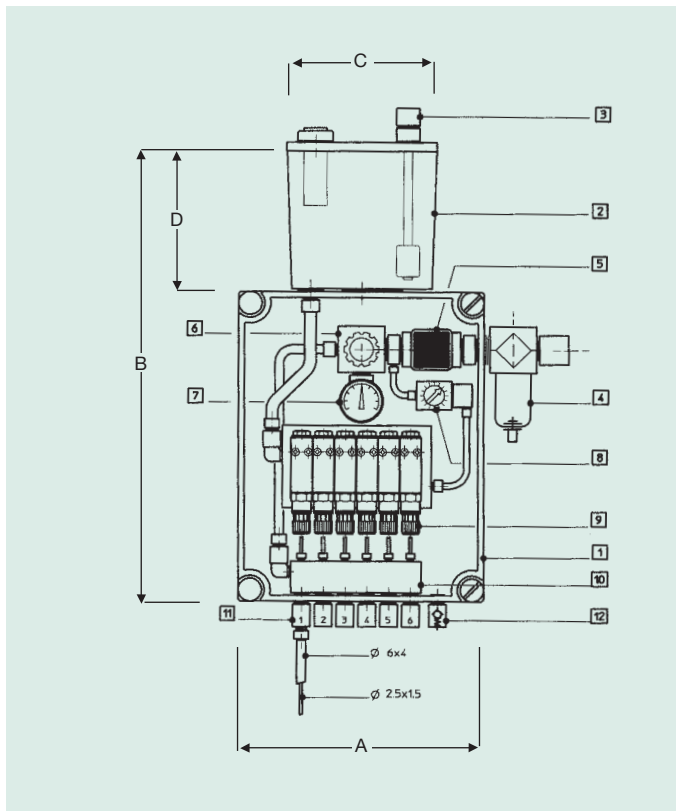

Lubrostar Cabinet with Pulse Generator and Low Level Switch

Part No.	Pump Units	A	B	C	D
LV 67641	1	200	420	120	130
LV 67642	2				
LV 67643	3				
LV 67644	4				
LV 67645	5				
LV 67646	6				

Lubrostar Kits With or Without Pulse Generator

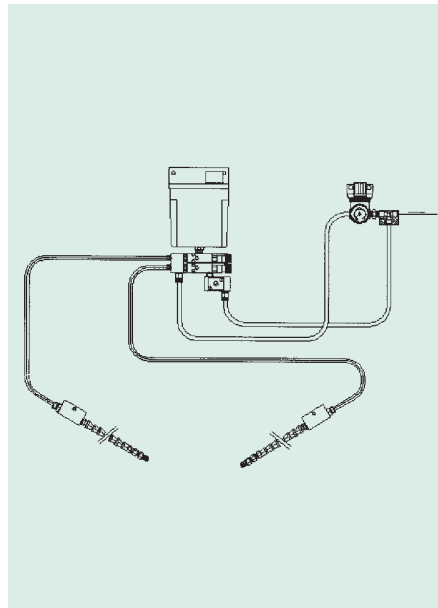

Lubrostar Kits With or Without Pulse Generator - Supplied Loose

- Each kits comprises of: Micro pump(s) & reservoir with or without pulse generator and low level switch, pressure reducing valve with guage.
- Pump Output: Adjustable from 0 to 30mm³ (minimum increment 0.7mm³).
- Number of Pumps: 1 or 2.
- Operating Frequency: From 3 strokes per second to 1 stroke per minute.
- Reservoirs: 0.4occ, 1.2 Ltr, 3 Ltr and 6 Ltr capacity. Material: Plastic.
- Pulse Generator: Adjustable from 3 strokes per second to 1 stroke per minute.
- Lubricants: Mineral or synthetic oils with a viscosity between 5 to 100 cSt and suitable for use with vitron seals and nylon tube.

Lubrostar Kits With or Without Pulse Generator - Panel Mounted

- Each kits comprises of: Micro pump(s) & reservoir with or without pulse generator and low level switch, 3/2 NO solenoid valve, pressure reducing valve with guage.
- Pump Output: Adjustable from 0 to 30mm³ (minimum increment 0.7mm³).
- Number of Pumps: 1 to 6.
- Operating Frequency: From 3 strokes per second to 1 stroke per minute.
- Solenoid Valve: Available with 24V DC
24V 50/60 Hz
110V 50/60 Hz
230V 50/60 Hz
- Reservoirs: 1.2 and 3 Litre capacity. Material: Plastic
- Pulse Generator: Adjustable from 3 strokes per second to 1 stroke per minute.
- Lubricants: Mineral or synthetic oils with a viscosity between 5 to 100 cSt and suitable for use with vitron seals and nylon tube.

Contact sales office for part numbers etc.

End Nozzles

3 types available with different jet shape
The width of jet is dependent on the distance between nozzles and their target.

Types

Part No.	Connector	Projection shape
LV 99518	1/8 BSP Seat	Narrow full cone (S)
LV 99519		Wide full cone (L)
LV 99520		Flat cone (P)
LV 98382		45° angle (X)

Narrow Cone

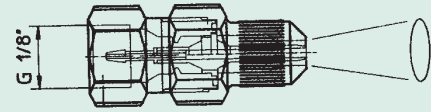

Wide Cone

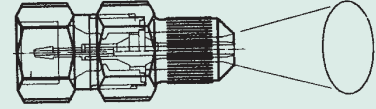

Flat Cone

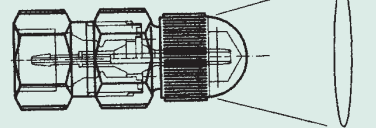

End Tubes (Swiveling)

Fitted with mounting block and nozzle,

Rigid type

Part No.	Bore mm	Nozzle Type	Tube Connection
LV 94988	4	Narrow Jet	6mm Ø
LV 94989		Wide Jet	
LV 94990		Flat Jet	

Rotary type

Part No.	Bore mm	Nozzle Type	Tube Connection
LV 94911	1/4 6.35mm	Narrow Jet	6mm Ø
LV 94992		Wide Jet	
LV 94993		Flat Jet	

Magnetic Base Only

Part No.	Thread	Dia. of Magnet
LV 94987	M6x1	32mm
LV 97734	M6x1	55mm

Micropump and Reservoir

Part No.	Pump Units	A	B	C	D	Res Lt.	Low Level Switch
LV 67667	1	71	219	38	10	0.4	No
LV 67669	2						No
LV 67677	1	123	244	105	13	1.2	No
LV 67678	1						Yes
LV 67679	2						No
LV 67680	2						Yes

Also available with Pulse Generator and Larger Capacity Reservoirs

Dimensions

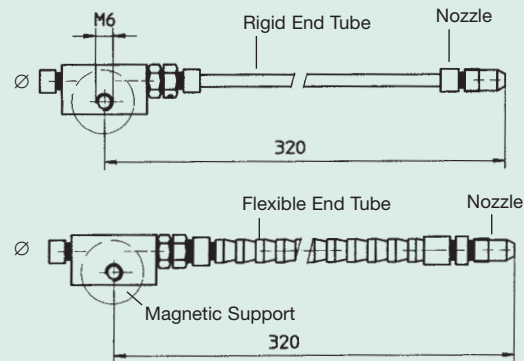

0.4 Lt

1.2 Lt

