

Adams



A wide range of tubing, hoses, connectors, rotating joints and adaptors, swivels, nipples, bushings and tubing clips etc is available.

Most Lubrication Systems now use metric tubing in sizes 4, 6, 8, 10 and 12mm \varnothing .

All Tubing used must be compatible with the type of system it is intended for, i.e. pressure, temperature and type of lubricant must be considered.

□ Fittings and Accessories

Tubing & Hoses - For sizes not shown below please ask

NYLON TUBE: Nylon (Polymide) Type 12, Fully Plasticised and Light Stabilised.
Metric Tube meets the requirement of Din 73378 and BS 5409

Max Working Pressure @ 20°C

Colour - Natural

Part No.	O/D	I/D	Max Pressure
40 1002 02	4	2.5	28
40 1002 04	6	4	24
40 1002 05	8	6	22
40 1002 06	10	7.5	

High Pressure Semi-Rigid

Colour - Black

Part No.	O/D	I/D	Short Time Burst Rating
135180	4	2	176 bar
151027	6	3	269 bar
136810	8	6	75 bar
136814	10	8	

Bundy Type: Double Wall Brazed Steel Tube, Copper Coated Steel Strip
with Tinned External Surface, 3 Metre Straight Lengths

Part No.	O/D	I/D	Max Pressure Bar
40 1066 02	4	2.6	380
40 1066 04	6	4.6	300
40 1066 05	8	6.6	250
40 1066 06	10	8.6	195

Copper Tube: Annealed 10 Metre Coils

Part No.	O/D	I/D	Max Pressure Bar
40 1026 02	4	2.8	128
40 1026 04	6	4.4	112
40 1026 05	8	6.4	81
40 1026 06	10	8.4	64

Copper Tube: Half-Hard 3 Metre Lengths

Part No.	O/D	I/D	Max Pressure Bar
40 1021 02	4	2.8	193
40 1021 04	6	4.0	218
40 1021 05	8	6.0	157
40 1021 06	10	7.6	150

Nylon Hose: Nylon 12 Inner Core
Polyester Fibre Braid, Polyurethane Outer Cover

Part No.	Bore	O/D	Max Working Pressure Bar
136005	3/16"	8	193

152166	1/4"	13	190
--------	------	----	-----

Fittings for Nylon Hose: Reusable, 2 Parts

Part No.	O/D	
25478-001	4	Complete Fitting
25477-761	6	Complete Fitting

Part No.		Thread	
Ferrule	Insert		
105775	60696	1/4 BSP	Straight Female
105775	105783	1/4 BSP	Straight Male

Rubber Hose: with Swaged Fittings Low Pressure (10 bar), for Single Line Proportional Systems

Part No.	Fittings
LV 91211 (State Length Required)	4mm Ø Stand Pipe each end AFLJ516

Rubber Hose: SAE 100RI, with Reusable Fittings
Medium Pressure (210 bar), for Progressive Grease Systems etc

Part No.	Fittings
LV 94400 (State Length Required)	4mm Ø Stand Pipe each end AFLB4
LV 94600 (State Length Required)	6mm Ø Stand Pipe each end AFLB6
LV 91274 (State Length Required)	1/8 BSP Male x 1/8 BSP Female Swivel AFLB18F/18G

Connectors - For use with BSP Hose Fittings

Part No.	A	B	L
LV 20137	1/8 BSP	1/8 BSP Taper	27.9
LV 20138		1/4 BSP Taper	29.8
LV 20139	1/4 BSP	3/8 BSP Taper	34.8
LV 20140			35.0

For other sizes please ask

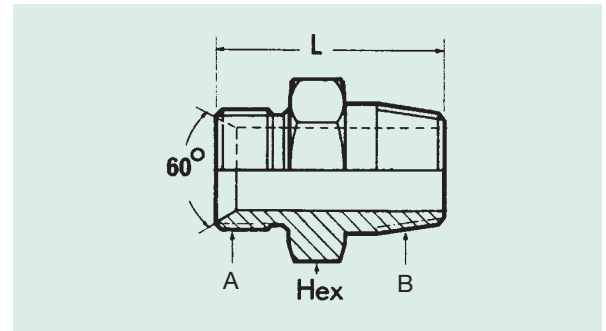

Non-Return Valves - Straight for use in Distributors

Part No.	A	B	L	Tube Size mm Ø
LV 95149	5/16 UNF	5/16 UNF	26	4
LV 90845	1/8 BSP	1/8 BSP	25	6
LV 90846	1/4 BSP		25	8
LV 90173		1/4 BSP	28	

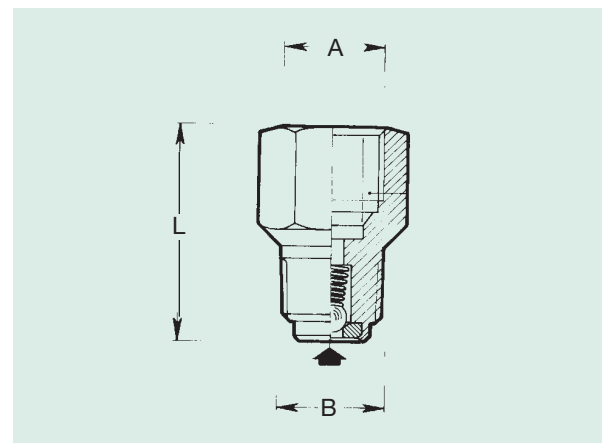

Non-Return Valves - Straight for use in Lubrication Point

Part No.	A	B	L	Tube Size mm Ø
LV 90182	8x1	1/8 BSP	25	4
LV 90849	1/8 BSP		26	6
LV 90850	1/4 BSP		28	8
LV 90188		1/4 BSP	28	

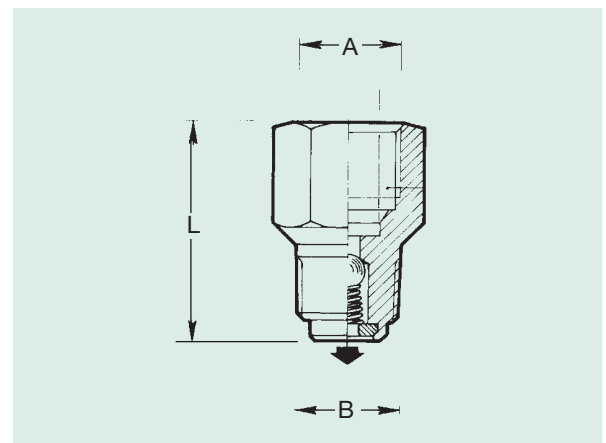

Non-Return Valve - 90° Elbow for use in Lubrication Point

Part No.	A	B	L	Tube Size mm Ø
LV 90852	1/8 BSP	1/4 BSP	17	6
LV 90192	1/4 BSP		20	8

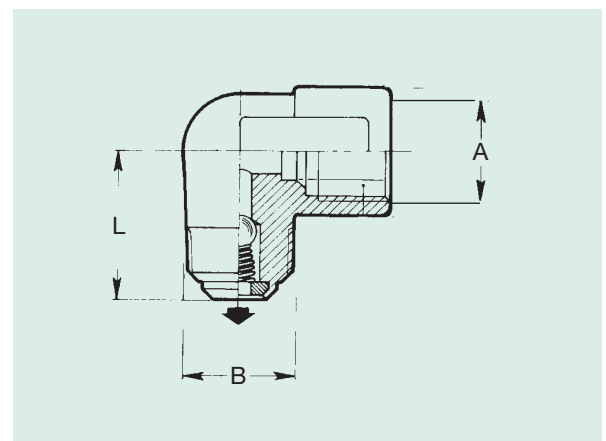

Tube Fittings - Straight taper thread

Part No.	Tube \varnothing	A	B Taper	L		
LV 91202	4	5/16 UNF	M8 x 1.25	17		
LV 90283			1/4 UNC	19		
LV 90278			1/8 NPT	16		
LV 90053		M8x1		M6 x 1	20	
LV 90054				M8x1	16	
LV 90055				M10x1	16	
LV 90056				M12x1	20	
LV 90057				1/8 BSP	16	
LV 90058				1/4 BSP	16	
LV 90059				6	M10x1	M8x1
LV 90060	M10x1	18				
LV 90061	M12x1	20				
LV 90062	1/8 BSP	18				
LV 90066	1/4 BSP	18				
LV 90067	M8 x 1.25	22				
LV 90068	M10 x 1.50	20				
LV 90069	M6 x 1	22				
LV 92875	8	1/4 BSP	M10 x 1			60
LV 90075			1/2 BSP			25
LV 90077			1/4 BSP			
LV 90079			1/8 BSP			
LV 90080			3/8 BSP			

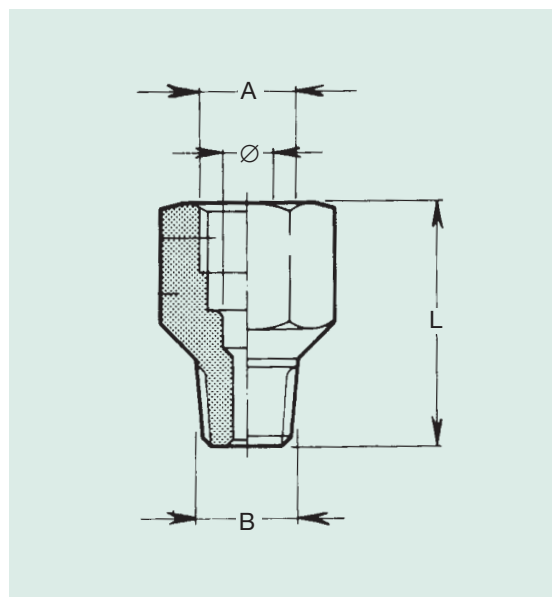

Reducing Adaptors

Part No.	A	B Taper	L
LV 90050	1/8 BSP	M6 x 1	20
LV 91119		M8 x 1	
LV 90052		M8 x 1.25	
LV 90700	M10x1	1/4 UNF	18
LV 90311	1/8 NPT	1/8 NPT	19
LV 90313	1/4 BSP	M12x1	25
LV 90149		1/4 BSP	45

Part No.	A	B Parallel	L
LV 90044	1/4 BSP	M12 x 1	25

Washers - Aluminium

Part No.	A	B Bore	C
LV 90338	5.5	3	1
LV 90328	7.2	4	
LV 91159	16.8	13.3	1.5
LV 90329	18	15.2	
LV 90796	12.6	10.2	
LV 90218	10.6	8.2	1
LV 91825	17	12.2	1.5

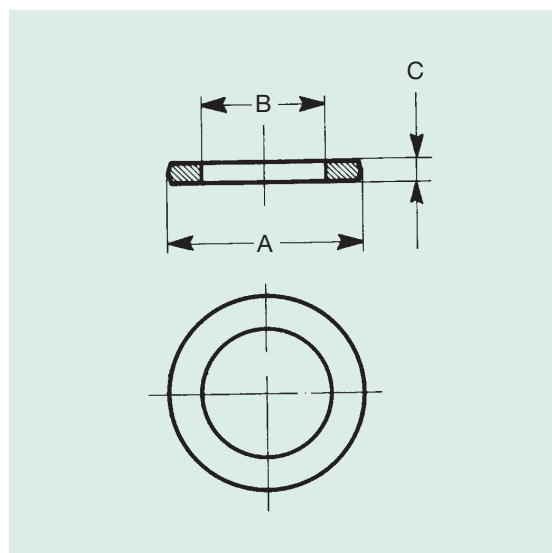

Tube Fittings - 90° Elbow

Part No.	Tube O/D	A	B Taper	L
LV 90159	4	5/16 UNF	1/8 NPT	15
LV 91207			1/4 UNC	
LV 90088		M8x1	M8 x 1	
LV 90089			M8 x 1.25	
LV 90090			M6 x 1	
LV 90091			1/8 BSP	
LV 90092			M10 x 1	
LV 90093			M10 x 1.50	
LV 90129			M12 x 1	
LV 90094			M12 x 1.75	
LV 90095			1/4 BSP	
LV 90096			M8 x 1	
LV 90097	M8 x 1.25			
LV 90098	1/8 BSP			
LV 90099	M10 x 1			
LV 90103	M6 x 1			
LV 90105	M10 x 1.50			
LV 90106	M12 x 1			
LV 90109	1/4 BSP			
LV 90049	8	1/4 BSP	M10 x 1	20
LV 90300			M10 x 1.50	
LV 91095			M12 x 1	
LV 90301			1/8 NPT	
LV 90117			1/4 BSP	24
LV 90119			1/8 BSP	
LV 90125			3/8 BSP	

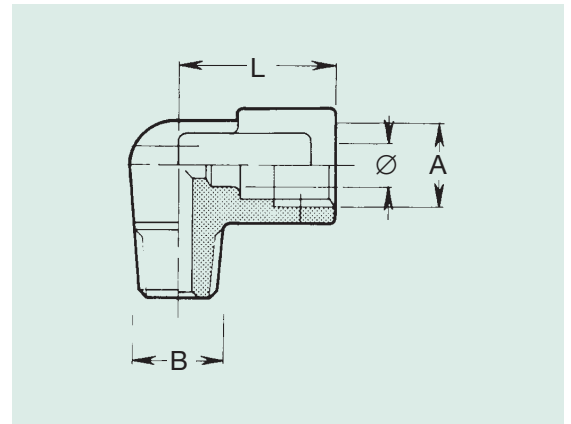

Adaptors - 90° Elbow - Without tube seating

Part No.	A	B Taper	L
LV 90114	1/4 BSP	1/4 BSP	20
LV 90115	1/8 BSP		17
LV 90116	3/8 BSP		25
LV 90118	1/4 BSP	1/8 BSP	20
LV 90123	3/8 BSP	3/8 BSP	24
LV 90124			



Anchor Blocks - Straight

Part No.	Tube \varnothing	Thread	L	H	S	F
LV 95102	4	5/16 UNF	24	8	13	7
LV 90887	6	1/8 BSP	30	12	14	5.2
LV 91403	8	1/4 BSP	34	14	20	8.5
LV 91405	10	3/8 BSP	40	18	30	

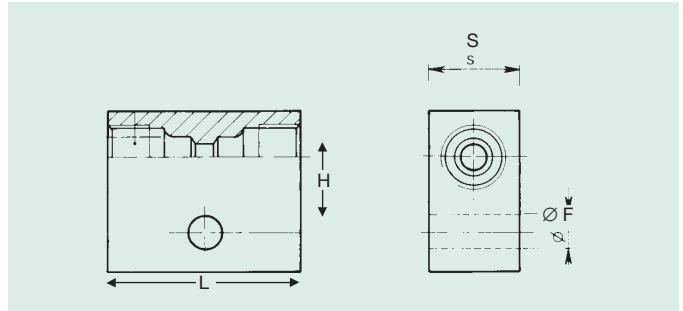
**Anchor Blocks - 90° Elbow**

Part No.	Tube \varnothing	Thread	L	H	S	F
LV 91179	4	5/16 UNF	20	8	12	7
LV 91393	6	1/4 BSP	30	13	20	8.5
LV 90888		1/8 BSP	25	12	14	5.2
LV 91416	8	1/4 BSP	30	14	20	8.5
LV 91418	10	3/8 BSP	40	20	30	

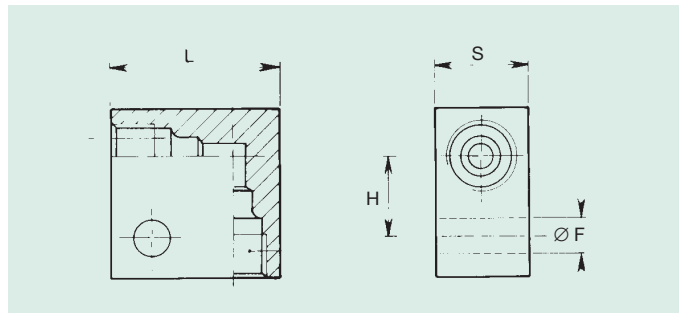
**Anchor Blocks - 90° Elbow, with "In-Line" Fixing Hole**

Part No.	Tube \varnothing	Thread	L	B	H	S	F
LV 90889	6	1/8 BSP	36	25	17	15	5.2
LV 91423	8	1/4 BSP	46	30	21	20	8.5
LV 91425	10	3/8 BSP	50	40	25	30	

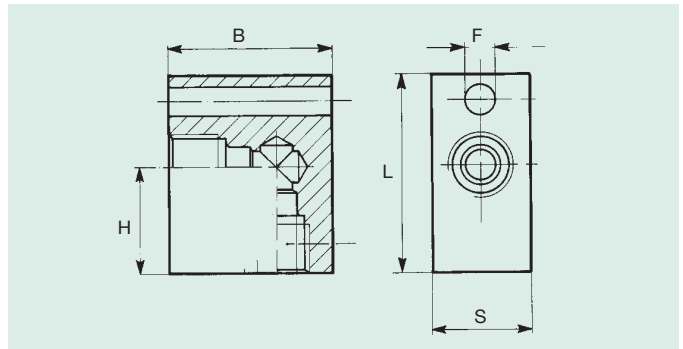
**Swivel Joints - Straight**

Pressure 100 bar - 300 rpm Max.

Part No.	A	B Taper	L
LV 90247	1/8 BSP	1/8 BSP	31
LV 90245		1/4 BSP	
LV 90243	1/4 BSP	1/8 BSP	38
LV 90241		1/4 BSP	

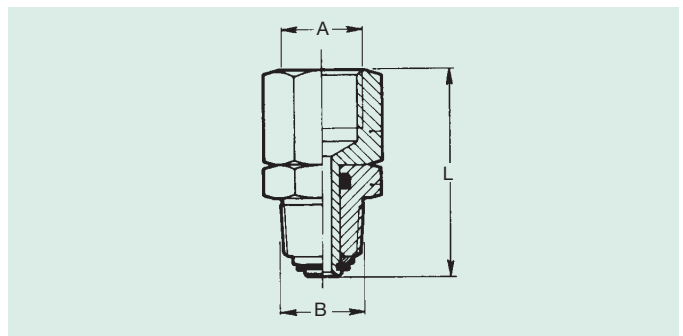
**Swivel Joints - Elbow 90°**

Pressure 100 bar - 300 rpm Max.

Part No.	A	B Taper	L
LV 90250	1/8 BSP	1/8 BSP	31
LV 90252	10x1mm		

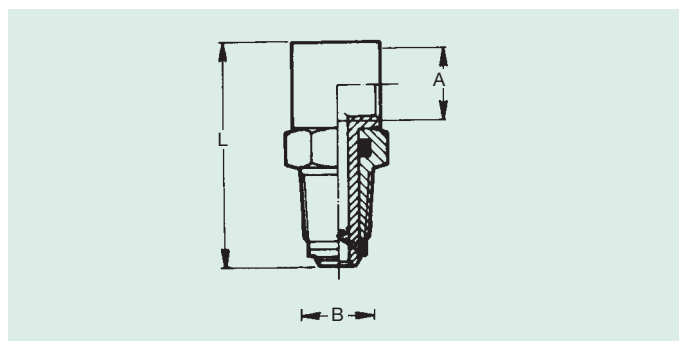

Tubing Nuts - For Bicone Sleeves

Part No.	Tube Ø	Thread A	H	h
LV 90440	4	M8 x 1	12	8
LV 90443		5/16 UNF		
LV 90460	6	M10 x 1	13	9
LV 90422		1/8 BSP	14.5	
LV 90480	8	M12 x 1	14	9.5
LV 90482		1/4 BSP	17	

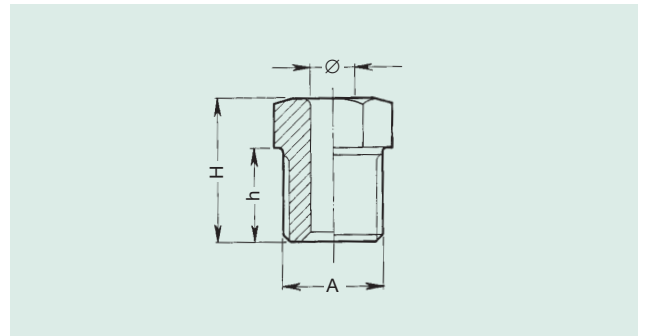

Bicone sleeves

Part No.	Tube Ø	D	H
LV 90540	4	6	5.5
LV 90560	6	8	6.5
LV 90580	8	10	
LV 90682*			10.4

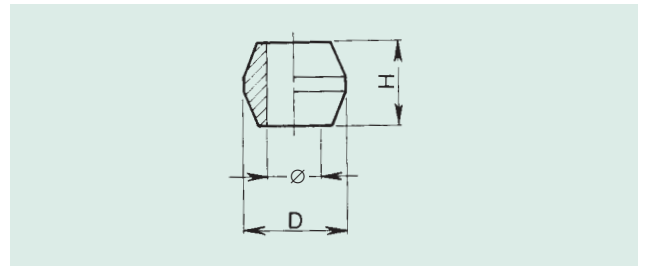

* Steel. Remainder Brass

Tubing Nuts - For Monocone Sleeves

Part No.	Tube Ø	Thread A	H	h
LV 90640	4	M8 x 1	13	8
LV 90643		5/16 UNF		
LV 90660	6	M10 x 1	14.5	8.5
LV 90664		1/8 BSP	13.5	9
LV 90680	8	M12 x 1	13.5	8.5

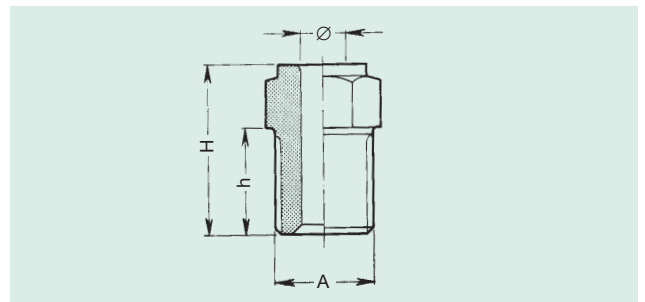

Female Tubing Nuts - For Monocone Sleeves

Part No.	Tube Ø	Thread A	H
LV 90740	4	M8 x 1	9.5
LV 90743		5/16 UNF	12.5
LV 90760	6	M10 x 1	11
LV 90780	8	M12 x 1	10

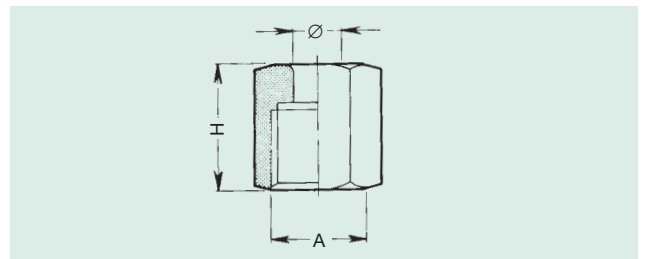

Monocone Sleeves

Part No.	Tube Ø	D	H
LV 90840	4	6.5	4
LV 90860	6	8	5
LV 90880	8	10.5	5.5

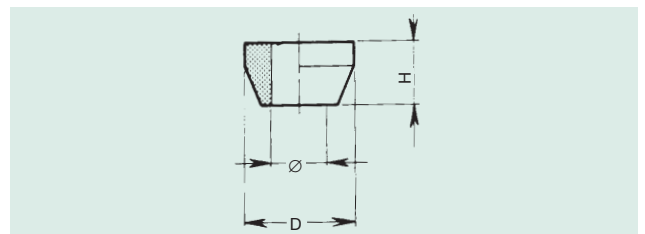

Support Insert - For Nylon Tube

Part No.	Tube Ø	d -0.05 -0.15	L
LV 90881	4	2.5	8.5
LV 90940		3	
LV 90960	6	4	10.5
LV 90980	8	6	11.5

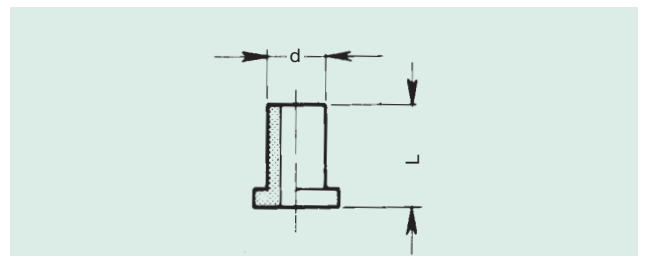

Blanking Plugs - hexagonal

Material - up to 3/8 BSP - Steel

1/2 to 1 BSP - Aluminium

Part No.	Thread Parallel	H	h
LV 20150	1/8 BSP	12	7
LV 20151	1/4 BSP	14.5	9.5
LV 20152	3/8 BSP	18	12
LV 20153	1/2 BSP	17	9
LV 20154	3/4 BSP	19	10
LV 20155	1 BSP	23.5	12.5

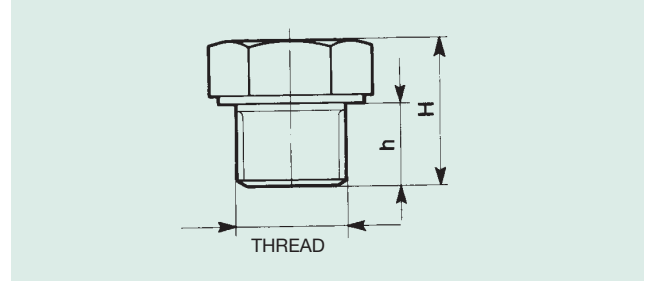
**Blanking Plugs - Hex Socket Material - Steel**

Part No.	Thread Taper	H	A/F
LV 20131	1/8 BSP	9.8	3/16
LV 20132	1/4 BSP	12.9	1/4
LV 20133	3/8 BSP	14.6	5/16

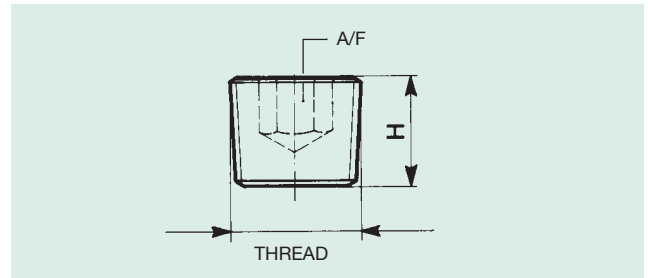
**Blanking Plugs - Tube Seating Material - Steel**

Part No.	Thread	H	h	S = Slotted H = Hex Head
LV 91503	8x1mm	10	4.5	S
LV 91513	5/16 UNF	15	10.5	H
LV 91504	10x1mm	10	4.5	S
LV 90638	1/8 BSP	19	14	H
LV 91505	12x1mm	11	5.5	S
LV 93532	1/4 BSP	20	14.5	H

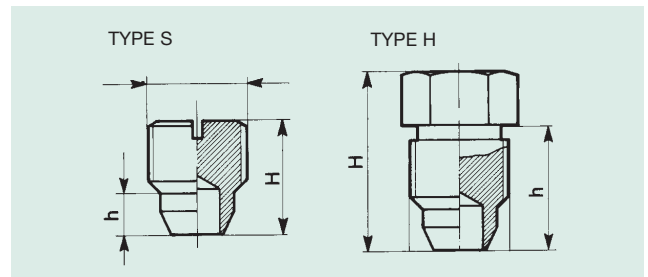
**Tube Clips**

Part No.	Tube Ø	Ways	D	L
LV 91836	4	1	5.5	-
LV 91837		2		-
LV 91838		3		-
LV 91839		4		30
LV 91843	6	1		-
LV 91844		2		-
LV 92213		3		-
LV 92214		4		40
LV 91845	8	1		-
LV 91846		2		-
LV 91851	10	1	-	

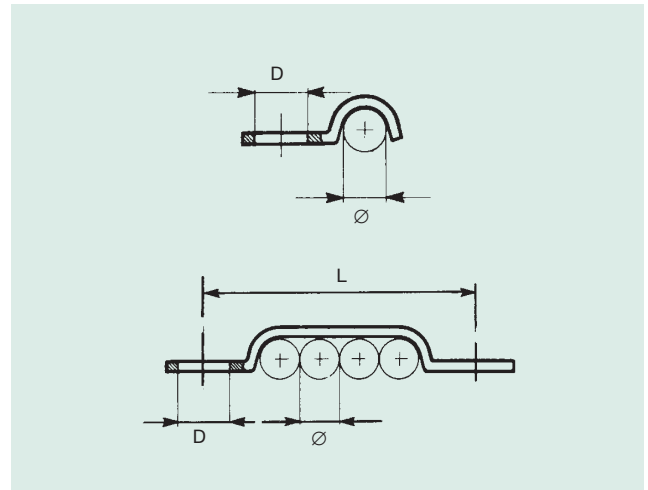

Metric Compression Fittings - A Range of Brass Fittings for Nylon, Bundy or Copper Tube

Straight Male Adaptor

Part No.	A Ø tube	B Thread BSP	D	
36 0530 02	4	1/8	18.5	
36 0530 03	5		20.0	
36 0530 04	6		20.0	
30 0530 05	8		26.5	
36 0530 06	10		28.0	
36 0530 08	4		1/4	18.0
36 0530 09	5	21.5		
36 0530 10	6	21.5		
36 0530 11	8	23.0		
36 0530 12	10	30.0		
36 0530 13	12	31.1		
36 0530 18	6	3/8	21.0	
36 0530 19	8		21.0	
36 0530 20	10		26.0	
36 0530 21	12		29.0	
36 0530 28	8		1/2	25.0
36 0530 29	10			27.0

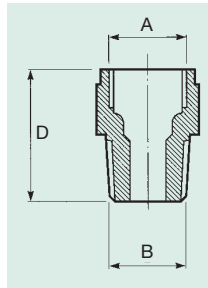

Male Elbow Adaptor

Part No.	A Ø Tube	B Thread BSP	G	J	J1	
36 0005 02	4	1/8	9.5	14.9	15.5	
36 0005 03	5			16.5	17.0	
36 0005 04	6			16.5	18.2	
36 0005 05	8			20.0	20.0	
36 0005 06	4			1/4	15.7	19.8
36 0005 09	5				16.5	19.8
36 0005 10	6	17.2	19.0			
36 0005 11	8	20.6	21.0			
36 0005 12	10	21.0	23.0			
36 0005 13	12	22.2	25.0			
36 0005 18	6	3/8	12.7	18.2	24.0	
36 0005 19	8			21.8	24.0	
36 0005 20	10			22.0	24.0	
36 0005 21	12			24.5	26.0	
36 0005 28	8			1/2	23.4	28.5
36 0005 29	10				24.9	28.5

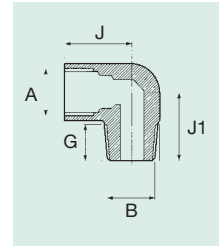

Nipped Adaptor

Part No.	A Ø Tube	B Thread BSP	D	
36 0556 02	4	1/8	26.0	
36 0556 03	5		27.5	
36 0556 04	6		27.5	
36 0556 05	8		30.0	
36 0556 08	4		1/4	28.5
36 0556 09	5			30.0
36 0556 10	6	30.0		
36 0556 11	8	32.0		
36 0556 12	10	33.5		
36 0556 19	8	3/8		37.0
36 0556 20	10		38.0	

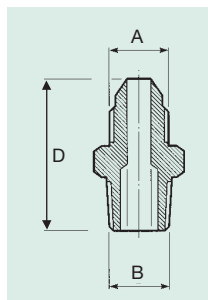

Elbow Connector

Part No.	A Ø Tube	J
36 0511 02	4	13.5
36 0511 03	5	15.5
36 0511 04	6	16.0
36 0511 05	8	20.0
36 0511 06	10	23.0

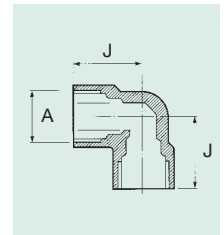

Straight Adaptor

Part No.	A Ø Tube	B Thread BSP	D	
36 0505 02	4	1/8	23	
36 0505 03	5		25	
36 0505 04	6		25	
36 0505 05	8		28	
36 0505 09	5		1/4	27
36 0505 10	6			27
36 0505 11	8	30		
36 0505 12	10	31		
36 0505 19	8	3/8		32
36 0505 20	10			33

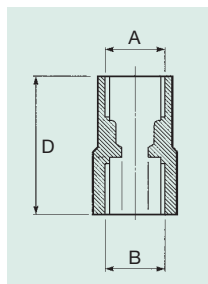

Straight Connector

Part No.	A Ø Tube	J
36 0503 02	4	22.0
36 0503 03	5	26.0
36 0503 04	6	26.0
36 0503 05	8	32.0
36 0503 06	10	35.0

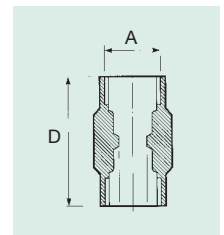

Nipped Adaptor

Part No.	A Ø Tube	B Thread BSP	D	
36 0557 02	4	1/8	24.0	
36 0557 03	5		24.5	
36 0557 04	6		24.5	
36 0557 10	6		1/4	28.0
36 0557 11	8			30.0
36 0557 12	10			31.5
36 0557 19	8	3/8		30.5
36 0557 20	10			32.0

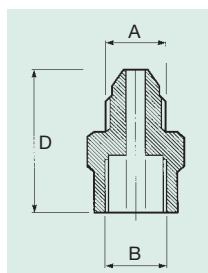

Bracketed Straight Connector

Part No.	A Ø Tube	D	D1
36 0552 02	4	24.0	14.9
36 0552 03	5	27.0	22.2
36 0552 04	6		
36 0552 05	8	33.3	24.6
36 0552 06	10	35.0	25.4

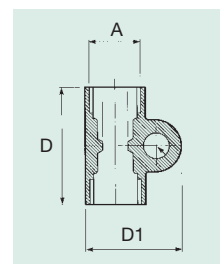

Tee Connector

Part No.	A Ø Tube	A1 Ø Tube	J	J1
36 0514 02	4	4	12.5	12.5
36 0514 03	5	5	15.5	15.5
36 0514 04	6	6	16.0	16.0
36 0514 05	8	8	20.0	20.0
36 0514 06	10	10	23.0	23.0

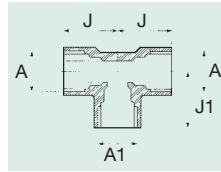

Bracketed Tee Connector

Part No.	A Ø Tube	D	J
36 0549 02	4	23.2	13.5
36 0549 03	5	31.1	16.0
36 0549 04	6	31.6	16.5
36 0549 05	8	36.4	20.5
36 0549 06	10	40.5	23.0

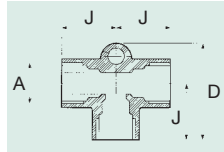

Bulkhead Connector

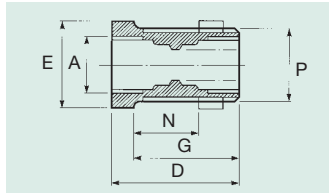

Part No.	A Ø Tube	D	E A/F	G	N Max Bulkhead Thread	P
36 0508 02	4	23	17	18	12	M12x1.0
36 0508 03	5	26	19	20	13	M15x1.0
36 0508 04	6	26	19	20	13	M15x1.0
36 0508 05	8	32	22	26	19	M18x1.5
36 0508 06	10	35	24	29	20	M20x1.5

Minimum bulkhead thickness 3.0mm.
Locknut should be ordered separately.

Bulkhead Locknut

Part No.	P Thread
36 0520 01	M12x1.0
36 0520 03	M15x1.0
36 0520 05	M18x1.5
36 0520 06	M20x1.5

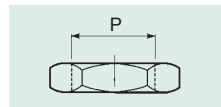

Tubing Nut

Part No.	A Ø Tube	D
36 0500 02	4	9.5
36 0500 03	5	10.0
36 0500 04	6	10.5
36 0500 05	8	12.1
36 0500 06	10	13.3

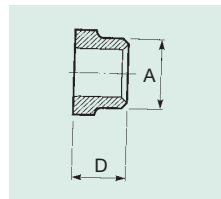

Tubing Plug

Part No.	A Ø Tube	D
36 0509 02	4	15.3
36 0509 03	5	17.0
36 0509 04	6	17.0
36 0509 05	8	19.5
36 0509 06	10	21.0

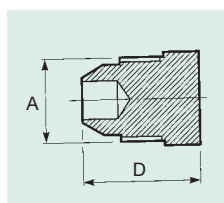

Universal Tubing Sleeve

Suitable for nylon and metallic tubing

Part No.	A Ø Tube	D
36 0501 02	4	4.2
36 0501 03	5	5.2
36 0501 04	6	5.5
36 0501 05	8	6.3
36 0501 06	10	7.0

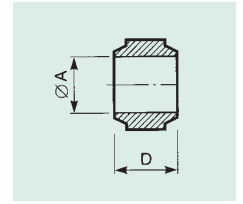

Folded Copper Washer

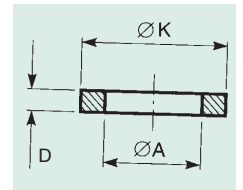

Part No.	A	Suitable for BSP Thread	or Metric Thread	or Imperial Thread	D	K
48 0213 01	9.8	1/8	-	3/8 x 24TPI	1.5	13.5
48 0213 02	13.2	1/4	-	-		17.7
48 0213 03	16.7	3/8	M16	-		21
48 0213 04	21.0	1/2	-	-	1.8	26.4
48 0213 05	23.0	5/8	-	-		28.6
48 0213 06	26.5	3/4	-	-		32.4
48 0213 07	30.2	7/8	M30	-	2.2	36.2
48 0213 08	33.3	1	M33	-		38.9
48 0213 09	42.0	1.1/4	-	-		49.9
48 0213 27	11.1	-	-	7/16 X 24 TPI	1.5	14.6
48 0213 28	12.7	-	-	1/2 X 24 TPI		17.7
48 0213 29	14.3	-	M14	9/16 X 24 TPI		18.5
48 0213 30	19.1	-	-	3/4 X 24 TPI	1.5	24.1
48 0213 41	8.3	-	M8	-		12
48 0213 42	10.3	-	M10	-		14
48 0213 43	12.1	-	M12	-		17

Bonded Washer

Part No.	A For BSP Thread	D	K
48 0215 01	1/8	2.1	16.0
48 0215 02	1/4		20.6
48 0215 03	3/8		23.8
48 0215 04	1/2	2.5	28.6
48 0215 05	5/8		31.7
48 0215 06	3/4		34.9

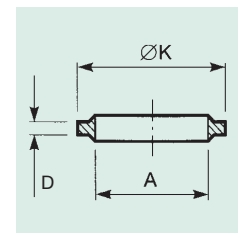

The Fittings shown are a small selection of the more commonly used range of Lubrication System Fittings. Please ask for details of any other requirement

Push-in Fittings - for use mainly with Nylon Tube, where the pressure is not likely to exceed 18 Bar

Straight Adaptor

- Ø tube to female parallel thread

Part No.	A Ø Tube	B Thread	C
102260405	4	M5x0.8	22.5
102260418	4	1/8 BSP	24.4
102260518	5		25.2
102260618	6		25.7
102260818	8		26.7
102260428	4	1/4 BSP	29.2
102260528	5		29.7
102260628	6		30.2
102260828	8		31.2
102261028	10	3/8 BSP	35.7
102261038	10		41.2

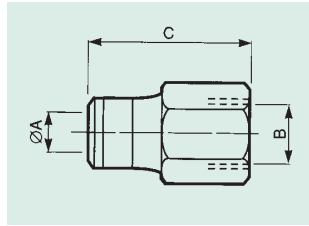

90° Swivel Elbow Adaptor -

Ø tube to male taper BSP thread

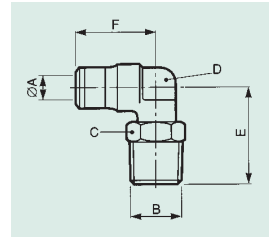

Part No.	A Ø Tube	B Thread BSP	C A/F	D A/F	E	F					
101470418	4	1/8	10.0	7.0	20.5	16.9					
101470518	5		11.0	9.0	21.0	18.4					
101470618	6		14.0	14.0	11.0	23.0	19.6				
101470818	8				13.3	25.5	21.3				
101471018	10	7.0			24.1	16.9					
101470428	4	9.0			24.6	18.4					
101470528	5	1/4	17.0	13.3	25.1	19.6					
101470628	6				26.1	21.3					
101470828	8				28.8	26.7					
101471028	10				31.8	31.7					
101471228	12	3/8	17.0	13.3	30.5	21.8					
101470838	8				22.0	13.3	34.2	26.7			
101471038	10							17.0	16.0	31.8	31.7
101471238	12										1/2
101471438	14	22.0	17.0	37.0							
101470848	8				1/2	16.0	38.2				
101471048	10							17.0	13.3	34.5	
101471248	12										22.0
101471448	14	1/2	17.0	37.0							

Straight Adaptor

- Ø tube to male taper BSP thread

Part No.	A Ø Tube	B Thread BSP	C
101250418	4	1/8	20.5
101250518	5		22.7
101250618	6		23.2
101250818	8		26.7
101251018	10	1/4	31.7
101250428	4		23.0
101250528	5		23.2
101250628	6		25.2
101250828	8	3/8	28.2
101251028	10		34.2
101251228	12		39.2
101250838	8		27.2
101251038	10	1/2	34.2
101251238	12		39.7
101251438	14		39.7
101250848	8		29.2
101251048	10	33.7	

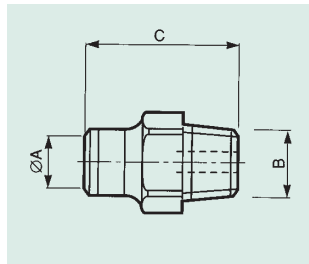

90° Swivel Elbow Adaptor -

Ø tube to male metric or parallel BSP thread

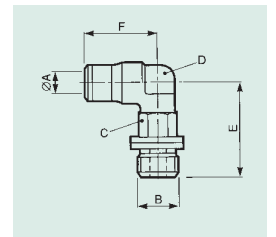

Elbow Adaptor

- Ø tube to male taper BSP thread

Part No.	A Ø Tube	B Thread BSP	D A/F	E	F						
101450418	4	1/8	7.0	15.0	16.9						
101450518	5			15.5	18.4						
101450618	6			16.0	19.6						
101450818	8			16.9	21.3						
101451018	10	1/4	13.3	18.5	26.7						
101450428	4			11.0	20.2	18.2					
101450528	5					23.3	20.0				
101450628	6						21.3				
101450828	8	26.7									
101451028	10	31.7									
101451228	12	3/8	16.0	23.3	31.7						
101450838	8				17.0	13.3	25.0	22.0			
101451038	10							1/2	16.0	28.8	26.7
101451238	12										24.2
101450848	8	17.0	13.3	32.2							
101451048	10				24.0	17.0	39.2				
101451248	12							1/2	16.0	43.0	

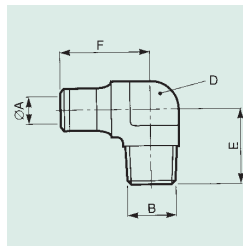

Part No.	A Ø Tube	B Thread	C	D A/F	E	F					
102470405	4	M5	8.0	7.0	19.5	17.0					
102470505	5			9.0	20.0	18.4					
102470605	6			20.5	19.6						
102470418	4	1/8 BSP	11.0	7.0	21.8	16.9					
102470518	5			9.0	22.3	18.4					
102470618	6			22.8	19.6						
102470818	8			13.0	23.8	21.3					
102471018	10	1/4 BSP	17.0	13.3	26.3	26.7					
102470428	4			11.0	9.0	26.0	16.9				
102470528	5						17.0	11.0	29.1	21.3	
102470628	6									3/8 BSP	13.3
102470828	8	19.0	16.0								
102471028	10			1/2 BSP	13.3	39.3					
102471228	12						24.0	17.0	39.2		
102470838	8									1/2 BSP	16.0
102471038	10	17.0	13.3								
102471238	12			24.0	17.0	39.2					
102471438	14						1/2 BSP	16.0	43.0		
102470848	8									17.0	13.3
102471048	10	24.0	17.0								
102471248	12			1/2 BSP	16.0	43.0					
102471448	14						17.0	13.3	37.0		

Supplied complete with sealing washer

Straight Connector - ∅ tube to ∅ tube

Part No.	A ∅ Tube	B
100200400	4	29.8
100200500	5	31.9
100200600	6	32.4
100200800	8	34.4
100201000	10	43.4

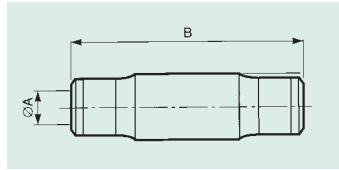

Bulkhead Connector

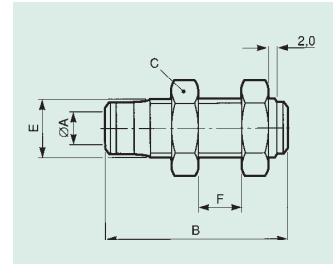

45° Swivel Elbow Adaptor - ∅ tube to male parallel BSP thread

Part No.	A ∅ Tube	B Thread BSP	C A/F	E	F
102570618	6	1/8	11.0	19.3	17.7
102570818	8			20.6	19.5
102570628	6	1/4	17.0	23.0	17.7
102570828	8			25.9	19.5

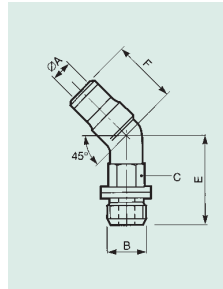

Part No.	A ∅ tube	B	C A/F	E Thread	F Max.
100290400	4	29.8	14	M10x1.0	12
100290500	5	31.9	17	M12x1.0	14
100290600	6	32.4	19	M14x1.5	15
100290800	8	34.4	22	M16x1.5	16
100291000	10	43.4	27	M20x1.5	14
100291200	12	50.4	30	M24x1.5	15
100291400	14				

Fitting is supplied with two locknuts.
Additional locknuts must be ordered separately.
Connectors will accommodate
up to 15 mm thickness of bulkhead according to model.

Anti-Vibration Mountings

Part No.	A	B	C	D
LV 10468	20	20	M6	15
LV 10568	30		M8	20

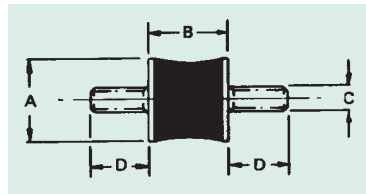

There are four of these to a set and they come complete with nuts and washers.

Bolts are threaded to within 2 pitches of the metal plates.

It is recommended that in applications where vibrations are present the above mountings should be used.

Anti-Vibration Plate

A heavily ribbed rubber plate material used to reduce vibration between combined pump / timers and machine base.

Dimensions are for mounting bracket on oil reservoir.

Four sizes available to suit 1.2 Lt, 2.0 Lt, 3.0 Lt and 5.0 Lt Reservoirs.

Part No.	A	B	C	D	To Suit Res. Capacity	No. of Holes
LV 10564	105	35	7	123	1.2 Lt	2
LV 10565	125	45		155	2.0 Lt	
LV 10566	194	76	9	210	3.0 Lt	4
LV 10567	218			248	5.0 Lt	

